



INSTRUCTION & SAFETY MANUAL

5 A SIL 3 Relay Output Module for NE or ND Loads,
with NE Relay condition,
DIN-Rail,
Model D5290S-084



General Description:

The D5290S-084 is a relay module suitable for the switching of safety related circuits, up to SIL 3 level according to IEC 61508:2010 Ed. 2 for high risk industries. It provides isolation between input channel and output contacts.
The input channel requires 110 Vdc voltage signal to drive the relay coils.

See the following pages for Functional Safety applications with related SIL value.

Mounting on standard DIN-Rail in Safe Area / Non Hazardous Location.



Functional Safety Management Certification:

G.M. International is certified by TUV to conform to IEC61508:2010 part 1 clauses 5-6 for safety related systems up to and included SIL3.

Technical Data

Input: 110 Vdc nom (100 to 125 Vdc).

Current consumption @ 110 Vdc: 15 mA with relay energized, typical.

Power dissipation: 1.7 W with 110 Vdc input voltage, relay energized, typical.

Isolation (Test Voltage): Input / All Outputs: 2.5 KV; Out S_1 & Out P_1 / Out S_3 & Out P_2, Out S_2, Out S_4: 500 V;
Out S_3 & Out P_2 / Out S_2, Out S_4: 500 V; Out S_2 / Out S_4: 500 V.

Output: 2 voltage free SPDT (= NO contact + parallel of 2 NC contacts) relay contacts identified with outputs: Out S_1 & Out P_1 and Out S_3 & Out P_2;
2 voltage free SPST (NO) relay contacts identified with: Out S_2 and Out S_4.

Terminals 13-14 (Out S_1), 15-16 (Out S_2), 21-22 (Out S_4) and 23-24 (Out S_3) are: open when relay is de-energized, closed in energized relay condition.
Terminals 17-18 (Out P_1) and 19-20 (Out P_2) are: closed when relay is de-energized, open in energized relay condition.

Contact material: Ag Alloy (Cd free).

Contact rating: 5 A 250 Vac 1250 VA, 5 A 250 Vdc 175 W (resistive load).

Contact inrush current: 8 A at 30 Vdc, 250 Vac.

DC Load breaking capacity:

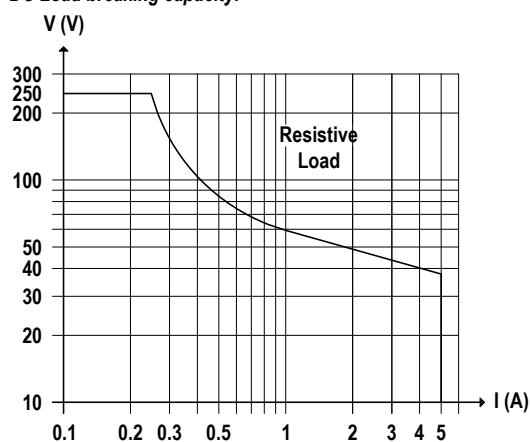

Mechanical / Electrical life: $10 * 10^6 / 5 * 10^4$ operation, typical.

Bounce time NO / NC contact: 4 / 10 ms, typical.

Frequency response: 10 Hz maximum.

Compatibility:

CE mark compliant, conforms to Directive: 2014/30/EU EMC, 2014/35/EU LVD, 2011/65/EU RoHS.

Environmental conditions:

Operating: temperature limits - 40 to + 60 °C, relative humidity 95 %, up to 55 °C.

Storage: temperature limits - 45 to + 80 °C.



Approvals:

UL & C-UL E477485 conforms to ANSI/UL508

TÜV Certificate No. C-IS-224248-01, SIL 2 / SIL 3 conforms to IEC61508:2010 Ed.2.

TÜV Certificate No. C-IS-236198-09, SIL 3 Functional Safety Certificate conforms to IEC61508:2010 Ed.2, for Management of Functional Safety.

DNV No.A-13625 and KR No. MIL20769-EL002 Certificates for maritime applications.

Mounting:

T35 DIN-Rail according to EN50022.

Weight: about 145 g.

Connection: by polarized plug-in disconnect screw terminal blocks to accommodate terminations up to 2.5 mm².

Location: Safe Area / Non Hazardous Location.

Protection class: IP 20.

Dimensions: Width 22.5 mm, Depth 123 mm, Height 120 mm.

Ordering Information

Model: D5290S-084

DIN-Rail accessories: Cover and fix MCHP196

Front Panel and Features



- SIL 3 according to IEC 61508:2010 Ed. 2 for Tproof = 10 / 20 years ($\leq 10\%$ / $> 10\%$ of total SIF) with PFDavg (1 year) 7.01 E-06, SFF = 99.01 % for two NE loads (see application n° 1, 2) or two ND loads (see application n° 4) with NE relay condition.
- SIL 2 according to IEC 61508:2010 Ed. 2 for Tproof = 7 / 20 years ($\leq 10\%$ / $> 10\%$ of total SIF) with PFDavg (1 year) 1.40 E-04, SFF = 60.42 % for four NE loads with NE relay condition (see application n° 3).
- Systematic capability SIL 3.
- 5 A SIL 3 / SIL 2 contacts for NE or ND loads with NE Relay condition.
- 8 A inrush current at 30 Vdc / 250 Vac.
- Input/Output isolation.
- EMC Compatibility to EN61000-6-2, EN61000-6-4, EN61326-1, EN61326-3-1 for safety system.
- UL & C-UL, TÜV Certifications.
- TÜV Functional Safety Certification.
- Type Approval Certificate DNV and KR for maritime applications.
- Simplified installation using standard DIN-Rail and plug-in terminal blocks.

Terminal block connections

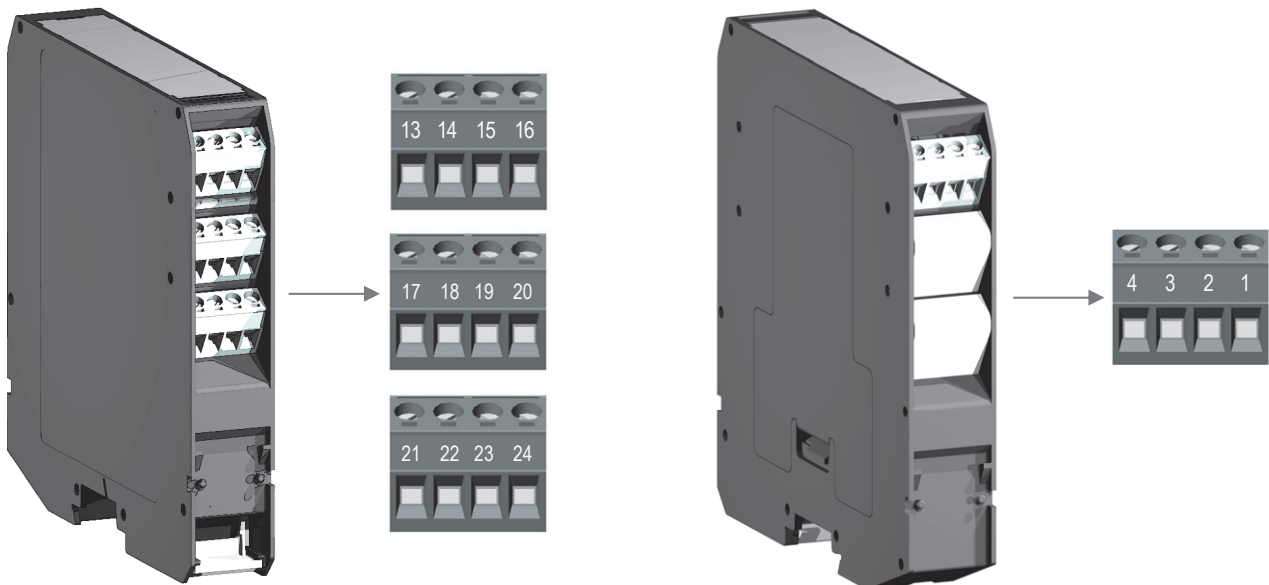

SAFE AREA

13	Normally Open (NO) contact (Out S_1)
14	
15	Normally Open (NO) contact (Out S_2)
16	
17	Normally Closed (NC) contact (Out P_1)
18	
19	Normally Closed (NC) contact (Out P_2)
20	
21	Normally Open (NO) contact (Out S_4)
22	
23	Normally Open (NO) contact (Out S_3)
24	

1	110 Vdc Input (+)
3	
2	110 Vdc Input (-)
4	

SAFE AREA / NON HAZARDOUS LOCATION

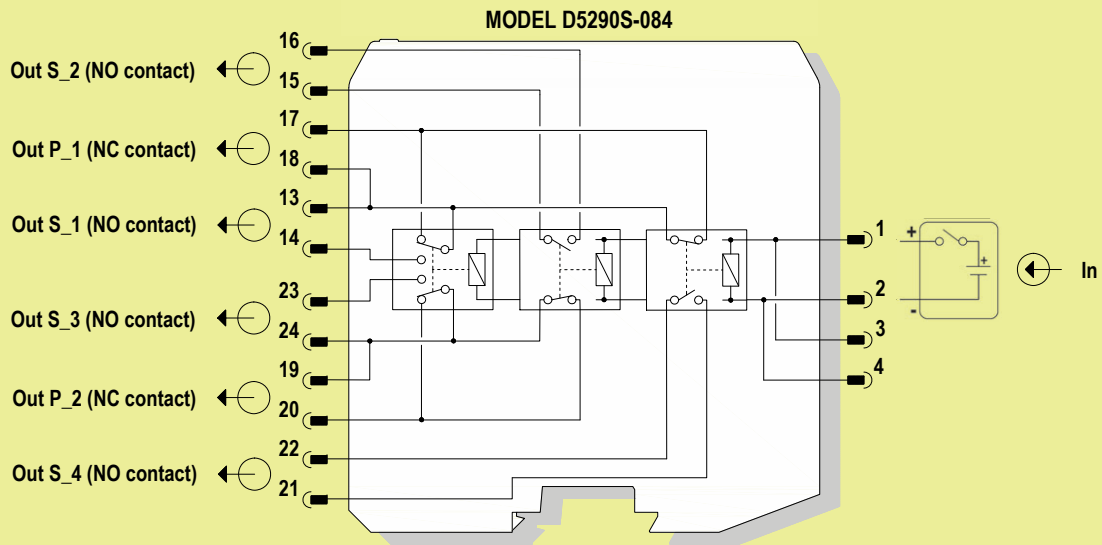

See the following pages for Functional Safety applications with related SIL value.

Relay contacts shown in de-energized position.
 Terminals 13-14, 15-16, 21-22 and 23-24 are open.
 Terminals 17-18 and 19-20 are closed.

To prevent relay contacts from damaging, connect an external protection (fuse or similar),
 chosen according to the relay breaking capacity diagram.

1) Application D5290S-084 - SIL 3 Load Normally Energized Condition (NE) and Normally Energized Relay: one common driving signal from PLC for both NE loads (A and B), with interruption of both load supply lines

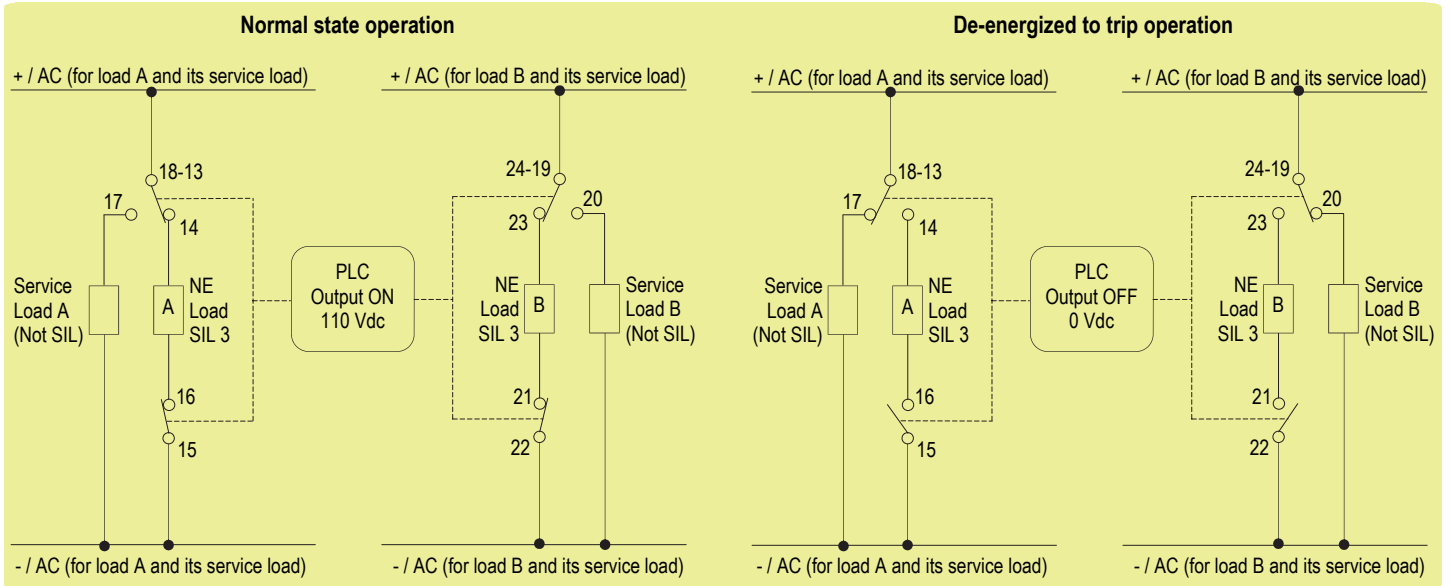

Description:

Input Signal from PLC/DCS is normally High (110 Vdc) and is applied to pins 1-2 or 3-4 in order to Normally Energize (NE) the internal relays.
 Input Signal from PLC/DCS is Low (0 Vdc) during "de-energize to trip" operation, in order de-energize the internal relays.
 Load A (and Load B if present) is Normally Energized (NE) therefore its safe state is to be de-energized.
 Disconnection of Loads A and B is done on both supply lines.
 Service Load A (and Service Load B if present) is normally de-energized, therefore it energizes during "de-energize to trip" operation.
 The following table describes the status (open or closed) of each output contact when input signal is High or Low.

Operation	Input Signal Pins 1-2 or 3-4	Pins 13-14	Pins 15-16	Pins 23-24	Pins 21-22	NE Load A (SIL3)	NE Load B (SIL 3)	Pins 17-18	Pins 19-20	Service Load A	Service Load B
						Pins 14-16	Pins 23-21				
Normal	High (110 Vdc)	Closed	Closed	Closed	Closed	Energized	Energized	Open	Open	De-Energized	De-Energized
Trip	Low (0 Vdc)	Open	Open	Open	Open	De-Energized	De-Energized	Closed	Closed	Energized	Energized

Safety Function and Failure behavior:

D5290S-084 is considered to be operating in Low Demand mode, as a Type A module, having Hardware Fault Tolerance (HFT) = 0.
 In the 1st Functional Safety application, the normal state operation of relay module is energized, with NE (Normally Energized) loads.
 In case of alarm or request from process, the relay module is de-energized (safe state), de-energizing loads.

The failure behaviour of relay module is described by the following definitions:

- fail-Safe State: it is defined as the output load being de-energized;
- fail Safe: this failure causes the system to go to the defined fail-safe state without a process demand;
- fail Dangerous: failure mode that does not respond to a demand from the process (i.e. being unable to go to the defined fail-safe state), so that the output load remains energized.

In addition, there are other definitions of failure behaviours which are not safety-related:

- fail "No effect": failure mode of a component that plays a part in implementing the safety function but is neither a safe failure nor a dangerous failure;
- fail "Not part": failure mode of a component which is not part of the safety function but part of the circuit diagram and is listed for completeness. When calculating the SFF this failure mode is not taken into account. It is also not considered for the total failure rate evaluation.

Failure rate data: taken from Siemens Standard SN29500.

Failure rate table:

Failure category	Failure rates (FIT)
λ_{dd} = Total Dangerous Detected failures	0.00
λ_{du} = Total Dangerous Undetected failures	1.60
λ_{sd} = Total Safe Detected failures	0.00
λ_{su} = Total Safe Undetected failures	159.48
$\lambda_{tot\ safe}$ = Total Failure Rate (Safety Function) = $\lambda_{dd} + \lambda_{du} + \lambda_{sd} + \lambda_{su}$	161.08
MTBF (safety function, single channel) = $(1 / \lambda_{tot\ safe}) + MTTR$ (8 hours)	708 years
$\lambda_{no\ effect}$ = "No effect" failures	17.12
$\lambda_{not\ part}$ = "Not Part" failures	0.00
$\lambda_{tot\ device}$ = Total Failure Rate (Device) = $\lambda_{tot\ safe} + \lambda_{no\ effect} + \lambda_{not\ part}$	178.20
MTBF (device, single channel) = $(1 / \lambda_{tot\ device}) + MTTR$ (8 hours)	640 years
MTTF _S (Total Safe) = $1 / (\lambda_{sd} + \lambda_{su})$	715 years
MTTF _D (Dangerous) = $1 / \lambda_{du}$	71347 years

Failure rates table according to IEC 61508:2010 Ed.2 :

λ_{sd}	λ_{su}	λ_{dd}	λ_{du}	SFF
0.00 FIT	159.48 FIT	0.00 FIT	1.60 FIT	99.01%

PFDavg vs T[Proof] table (assuming Proof Test coverage of 99%), with determination of SIL supposing module contributes ≤10% of total SIF dangerous failures:

T[Proof] = 1 year	T[Proof] = 10 years
PFDavg = 7.01 E-06 Valid for SIL 3	PFDavg = 7.01 E-05 Valid for SIL 3

PFDavg vs T[Proof] table (assuming Proof Test coverage of 99%), with determination of SIL supposing module contributes >10% of total SIF dangerous failures:

T[Proof] = 20 years
PFDavg = 1.40 E-04 Valid for SIL 3

Systematic capability SIL 3.

2) Application D5290S-084 - SIL 3 Load Normally Energized Condition (NE) and Normally Energized Relay: one common driving signal from PLC for both NE loads (A and B), with interruption of only one load supply line

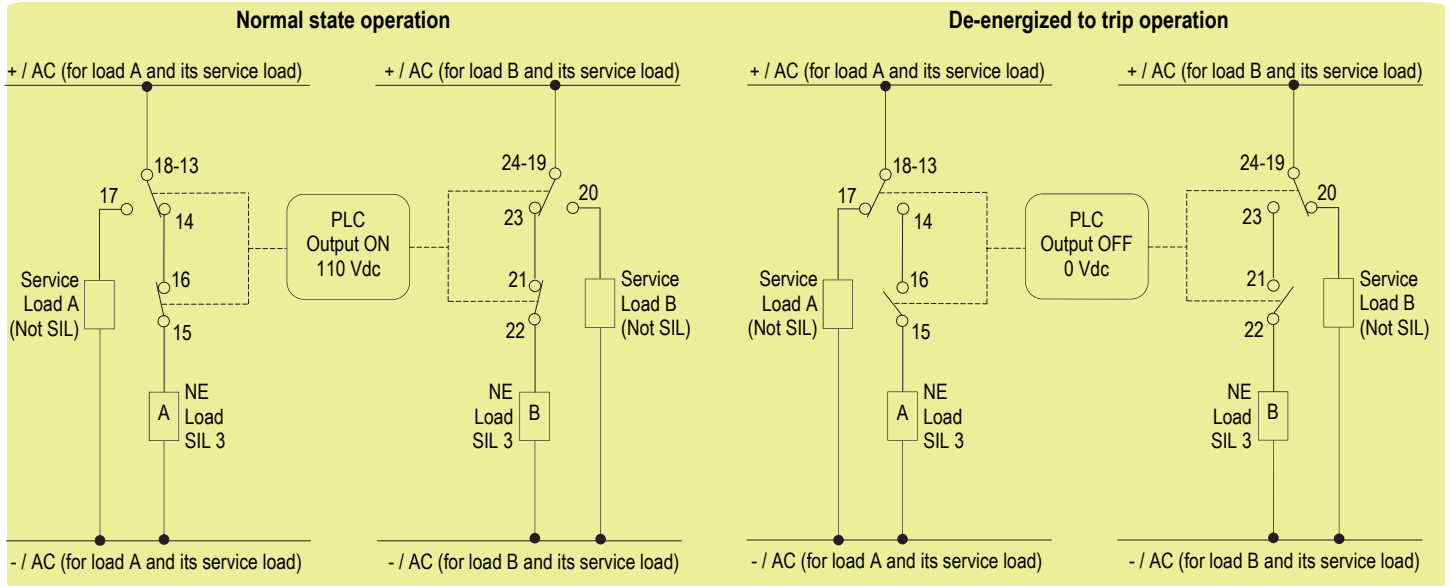

Description:

Input Signal from PLC/DCS is normally High (110 Vdc) and is applied to pins 1-2 or 3-4 in order to Normally Energize (NE) the internal relays.
 Input Signal from PLC/DCS is Low (0 Vdc) during “de-energize to trip” operation, in order de-energize the internal relays.
 Load A (and Load B if present) is Normally Energized (NE) therefore its safe state is to be de-energized.
 Disconnection of Loads A and B is done by disconnecting one supply line via two separate contacts.
 Service Load A (and Service Load B if present) is normally de-energized, therefore it energizes during “de-energize to trip” operation.
 The following table describes the status (open or closed) of each output contact when input signal is High or Low.

Operation	Input Signal Pins 1-2 or 3-4	Pins 13-14	Pins 15-16	Pins 23-24	Pins 21-22	NE Load A (SIL3) Pins 15-Supply	NE Load B (SIL 3) Pins 22-Supply	Pins 17-18	Pins 19-20	Service Load A	Service Load B
Normal	High (110 Vdc)	Closed	Closed	Closed	Closed	Energized	Energized	Open	Open	De-Energized	De-Energized
Trip	Low (0 Vdc)	Open	Open	Open	Open	De-Energized	De-Energized	Closed	Closed	Energized	Energized

Safety Function and Failure behavior:

D5290S-084 is considered to be operating in Low Demand mode, as a Type A module, having Hardware Fault Tolerance (HFT) = 0.
 In the 2nd Functional Safety application, the normal state operation of relay module is energized, with NE (Normally Energized) loads.
 In case of alarm or request from process, the relay module is de-energized (safe state), de-energizing loads.

The failure behaviour of relay module is described by the following definitions:

- fail-Safe State: it is defined as the output load being de-energized;
 - fail Safe: this failure causes the system to go to the defined fail-safe state without a process demand;
 - fail Dangerous: failure mode that does not respond to a demand from the process (i.e. being unable to go to the defined fail-safe state), so that the output load remains energized.
- In addition, there are other definitions of failure behaviours which are not safety-related:
- fail “No effect”: failure mode of a component that plays a part in implementing the safety function but is neither a safe failure nor a dangerous failure;
 - fail “Not part”: failure mode of a component which is not part of the safety function but part of the circuit diagram and is listed for completeness. When calculating the SFF this failure mode is not taken into account. It is also not considered for the total failure rate evaluation.

Failure rate date: taken from Siemens Standard SN29500.

Failure rate table:

Failure category	Failure rates (FIT)
λ_{dd} = Total Dangerous Detected failures	0.00
λ_{du} = Total Dangerous Undetected failures	1.60
λ_{sd} = Total Safe Detected failures	0.00
λ_{su} = Total Safe Undetected failures	159.48
$\lambda_{tot\ safe}$ = Total Failure Rate (Safety Function) = $\lambda_{dd} + \lambda_{du} + \lambda_{sd} + \lambda_{su}$	161.08
MTBF (safety function, single channel) = $(1 / \lambda_{tot\ safe}) + MTTR$ (8 hours)	708 years
$\lambda_{no\ effect}$ = “No effect” failures	17.12
$\lambda_{not\ part}$ = “Not Part” failures	0.00
$\lambda_{tot\ device}$ = Total Failure Rate (Device) = $\lambda_{tot\ safe} + \lambda_{no\ effect} + \lambda_{not\ part}$	178.20
MTBF (device, single channel) = $(1 / \lambda_{tot\ device}) + MTTR$ (8 hours)	640 years
MTTF _S (Total Safe) = $1 / (\lambda_{sd} + \lambda_{su})$	715 years
MTTF _D (Dangerous) = $1 / \lambda_{du}$	71347 years

Failure rates table according to IEC 61508:2010 Ed.2 :

λ_{sd}	λ_{su}	λ_{dd}	λ_{du}	SFF
0.00 FIT	159.48 FIT	0.00 FIT	1.60 FIT	99.01%

PFDavg vs T[Proof] table (assuming Proof Test coverage of 99%), with determination of SIL supposing module contributes ≤10% of total SIF dangerous failures:

T[Proof] = 1 year	T[Proof] = 10 years
PFDavg = 7.01 E-06 Valid for SIL 3	PFDavg = 7.01 E-05 Valid for SIL 3

PFDavg vs T[Proof] table (assuming Proof Test coverage of 99%), with determination of SIL supposing module contributes >10% of total SIF dangerous failures:

T[Proof] = 20 years
PFDavg = 1.40 E-04 Valid for SIL 3

Systematic capability SIL 3.

3) Application D5290S-084 - SIL 2 Load Normally Energized Condition (NE) and Normally Energized Relay: one common driving signal from PLC for all NE loads (A, B, C and D), with interruption of only one load supply line

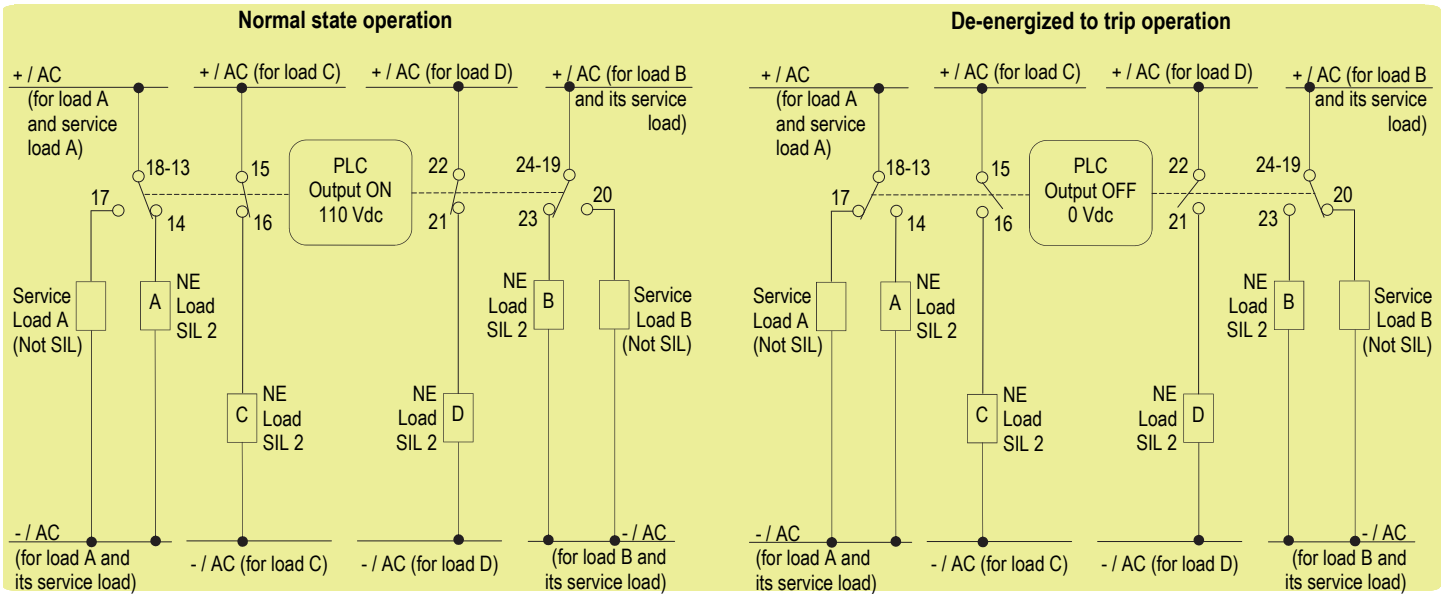

Description:

Input Signal from PLC/DCS is normally High (110 Vdc) and is applied to pins 1-2 or 3-4 in order to Normally Energize (NE) the internal relays.
 Input Signal from PLC/DCS is Low (0 Vdc) during "de-energize to trip" operation, in order de-energize the internal relays.
 Load A (and Load B, C, D if present) is Normally Energized (NE) therefore its safe state is to be de-energized.
 Disconnection of Loads A, B, C, D is done by disconnecting one supply line.
 Service Load A (and Service Load B if present) is normally de-energized, therefore it energizes during "de-energize to trip" operation.
 The following table describes the status (open or closed) of each output contact when input signal is High or Low.

Operation	Input Signal Pins 1-2 or 3-4	Pins 13-14	Pins 15-16	Pins 21-22	Pins 23-24	NE Load A (SIL 2) Pins 14-Supply	NE Load C (SIL 2) Pins 16-Supply	NE Load D (SIL 2) Pins 21-Supply	NE Load B (SIL 2) Pins 23-Supply	Pins 17-18	Pins 19-20	Service Load A	Service Load B
Normal	High (110 Vdc)	Closed	Closed	Closed	Closed	Energized	Energized	Energized	Energized	Open	Open	De-Energized	De-Energized
Trip	Low (0 Vdc)	Open	Open	Open	Open	De-Energized	De-Energized	De-Energized	De-Energized	Closed	Closed	Energized	Energized

Safety Function and Failure behavior:

D5290S-084 is considered to be operating in Low Demand mode, as a Type A module, having Hardware Fault Tolerance (HFT) = 0.
 In the 3rd Functional Safety application, the normal state operation of relay module is energized, with NE (Normally Energized) loads.
 In case of alarm or request from process, the relay module is de-energized (safe state), de-energizing loads.

The failure behaviour of relay module is described by the following definitions:

- fail-Safe State: it is defined as the output load being de-energized;
 - fail Safe: this failure causes the system to go to the defined fail-safe state without a process demand;
 - fail Dangerous: failure mode that does not respond to a demand from the process (i.e. being unable to go to the defined fail-safe state), so that the output load remains energized.
- In addition, there are other definitions of failure behaviours which are not safety-related:
- fail "No effect": failure mode of a component that plays a part in implementing the safety function but is neither a safe failure nor a dangerous failure;
 - fail "Not part": failure mode of a component which is not part of the safety function but part of the circuit diagram and is listed for completeness. When calculating the SFF this failure mode is not taken into account. It is also not considered for the total failure rate evaluation.

Failure rate date: taken from Siemens Standard SN29500.

Failure rate table:

Failure category	Failure rates (FIT)
λ_{dd} = Total Dangerous Detected failures	0.00
λ_{du} = Total Dangerous Undetected failures	32.00
λ_{sd} = Total Safe Detected failures	0.00
λ_{su} = Total Safe Undetected failures	48.84
$\lambda_{tot\ safe}$ = Total Failure Rate (Safety Function) = $\lambda_{dd} + \lambda_{du} + \lambda_{sd} + \lambda_{su}$	80.84
MTBF (safety function, single channel) = $(1 / \lambda_{tot\ safe}) + MTTR$ (8 hours)	1412 years
$\lambda_{no\ effect}$ = "No effect" failures	14.96
$\lambda_{not\ part}$ = "Not Part" failures	0.00
$\lambda_{tot\ device}$ = Total Failure Rate (Device) = $\lambda_{tot\ safe} + \lambda_{no\ effect} + \lambda_{not\ part}$	95.80
MTBF (device, single channel) = $(1 / \lambda_{tot\ device}) + MTTR$ (8 hours)	1191 years
MTTF _S (Total Safe) = $1 / (\lambda_{sd} + \lambda_{su})$	2337 years
MTTF _D (Dangerous) = $1 / \lambda_{du}$	3567 years

Failure rates table according to IEC 61508:2010 Ed.2 :

λ_{sd}	λ_{su}	λ_{dd}	λ_{du}	SFF
0.00 FIT	48.84 FIT	0.00 FIT	32.00 FIT	60.42%

PFDavg vs T[Proof] table (assuming Proof Test coverage of 99%), with determination of SIL supposing module contributes ≤10% of total SIF dangerous failures:

T[Proof] = 1 year	T[Proof] = 7 years
PFDavg = 1.40 E-04 Valid for SIL 2	PFDavg = 9.81 E-04 Valid for SIL 2

PFDavg vs T[Proof] table (assuming Proof Test coverage of 99%), with determination of SIL supposing module contributes >10% of total SIF dangerous failures:

T[Proof] = 20 years
PFDavg = 2.80 E-03 Valid for SIL 2

Systematic capability SIL 3.

4) Application D5290S-084 - SIL 3 Load Normally De-energized Condition (ND) and Normally Energized Relay: one common driving signal from PLC for both ND loads (A and B), with interruption of only one load supply line

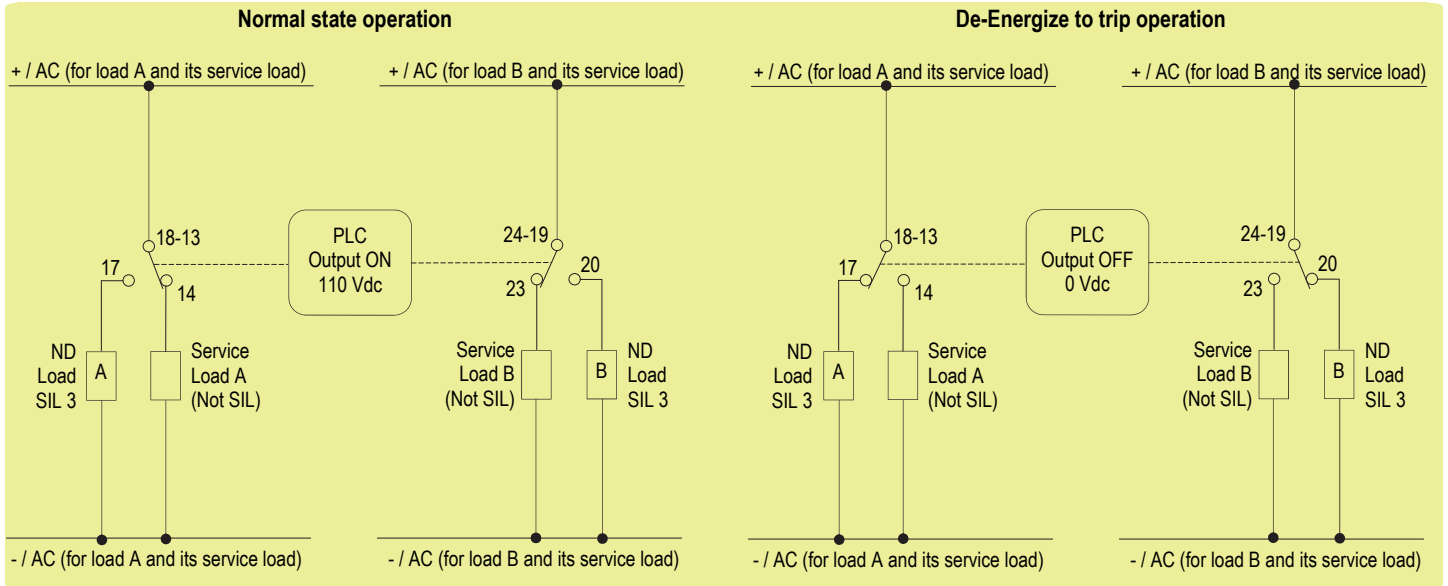

Description:

Input Signal from PLC/DCS is normally High (110 Vdc) and is applied to pins 1-2 or 3-4 in order to Normally Energize (NE) the internal relays.
 Input Signal from PLC/DCS is Low (0 Vdc) during "de-energize to trip" operation, in order de-energize the internal relays.
 Load A (and Load B if present) is Normally De-Energized (ND) therefore its safe state is to be energized.
 Disconnection of Loads A and B is done by disconnecting one supply line.
 Service Load A (and Service Load B if present) is normally energized, therefore it de-energizes during "de-energize to trip" operation.
 The following table describes the status (open or closed) of each output contact when input signal is High or Low.

Operation	Input Signal Pins 1-2 or 3-4	Pins 17-18	Pins 19-20	ND Load A (SIL3) Pins 17-Supply	ND Load B (SIL 3) Pins 20-Supply	Pins 13-14	Pins 23-24	Service Load A	Service Load B
Normal	High (110 Vdc)	Open	Open	De-Energized	De-Energized	Closed	Closed	Energized	Energized
Trip	Low (0 Vdc)	Closed	Closed	Energized	Energized	Open	Open	De-Energized	De-Energized

Safety Function and Failure behavior:

D5290S-084 is considered to be operating in Low Demand mode, as a Type A module, having Hardware Fault Tolerance (HFT) = 0.
 In the 4th Functional Safety application, the normal state operation of relay module is energized, with ND (Normally De-energized) loads.
 In case of alarm or request from process, the relay module is de-energized (safe state), energizing loads.
 The failure behaviour of all relay modules here considered is described by the following definitions:
 □ fail-Safe State: it is defined as the output load being energized;
 □ fail Safe: this failure causes the system to go to the defined fail-safe state without a process demand;
 □ fail Dangerous: failure mode that does not respond to a demand from the process (i.e. being unable to go to defined fail-safe state), so that output load remains de-energized.
 In addition, there are other definitions of failure behaviours which are not safety-related:
 □ fail "No effect": failure mode of a component that plays a part in implementing the safety function but is neither a safe failure nor a dangerous failure;
 □ fail "Not part": failure mode of a component which is not part of the safety function but part of the circuit diagram and is listed for completeness. When calculating the SFF this failure mode is not taken into account. It is also not considered for the total failure rate evaluation.
 Failure rate date: taken from Siemens Standard SN29500.

Failure rate table:

Failure category	Failure rates (FIT)
λ_{dd} = Total Dangerous Detected failures	0.00
λ_{du} = Total Dangerous Undetected failures	1.60
λ_{sd} = Total Safe Detected failures	0.00
λ_{su} = Total Safe Undetected failures	159.48
$\lambda_{tot\ safe}$ = Total Failure Rate (Safety Function) = $\lambda_{dd} + \lambda_{du} + \lambda_{sd} + \lambda_{su}$	161.08
MTBF (safety function, single channel) = $(1 / \lambda_{tot\ safe}) + MTTR$ (8 hours)	708 years
$\lambda_{no\ effect}$ = "No effect" failures	17.12
$\lambda_{not\ part}$ = "Not Part" failures	0.00
$\lambda_{tot\ device}$ = Total Failure Rate (Device) = $\lambda_{tot\ safe} + \lambda_{no\ effect} + \lambda_{not\ part}$	178.20
MTBF (device, single channel) = $(1 / \lambda_{tot\ device}) + MTTR$ (8 hours)	640 years
MTTF _S (Total Safe) = $1 / (\lambda_{sd} + \lambda_{su})$	715 years
MTTF _D (Dangerous) = $1 / \lambda_{du}$	71347 years

Failure rates table according to IEC 61508:2010 Ed.2 :

λ_{sd}	λ_{su}	λ_{dd}	λ_{du}	SFF
0.00 FIT	159.48 FIT	0.00 FIT	1.60 FIT	99.01%

PFDavg vs T[Proof] table (assuming Proof Test coverage of 99%), with determination of SIL supposing module contributes ≤10% of total SIF dangerous failures:

T[Proof] = 1 year	T[Proof] = 10 years
PFDavg = 7.01 E-06 Valid for SIL 3	PFDavg = 7.01 E-05 Valid for SIL 3

PFDavg vs T[Proof] table (assuming Proof Test coverage of 99%), with determination of SIL supposing module contributes >10% of total SIF dangerous failures:

T[Proof] = 20 years
PFDavg = 1.40 E-04 Valid for SIL 3

Systematic capability SIL 3.

Testing procedure at T-proof

The proof test shall be performed to reveal dangerous faults which are undetected by diagnostic. This means that it is necessary to specify how dangerous undetected faults, which have been noted during the FMEDA, can be revealed during proof test. The Proof test consists of the following steps:

Steps	Action
1	Bypass the safety-related PLC or take other appropriate action to avoid a false trip when removing the unit for test.
2	Verify the input-to-output functionality (for a min to max input voltage change 100 to 125 Vdc), considering the input signal and each relay output contact state: <ul style="list-style-type: none"> □ Out S_1 (NO contact) at terminals "13"- "14": when input is energized, Out S_1 must be closed; while shutdown of the input channel, Out S_1 must be open; □ Out S_2 (NO contact) at terminals "15"- "16": when input is energized, Out S_2 must be closed; while shutdown of the input channel, Out S_2 must be open; □ Out P_1 (2 NC contacts in parallel connection) at terminals "17"- "18": when input is energized, Out P_1 must be open; while shutdown of the input channel, Out P_1 must be closed; □ Out S_3 (NO contact) at terminals "23"- "24": when input is energized, Out S_3 must be closed; while shutdown of the input channel, Out S_3 must be open; □ Out S_4 (NO contact) at terminals "21"- "22": when input is energized, Out S_4 must be closed; while shutdown of the input channel, Out S_4 must be open; □ Out P_2 (2 NC contacts in parallel connection) at terminals "19"- "20": when input is energized, Out P_2 must be open; while shutdown of the input channel, Out P_2 must be closed.
3	Remove the bypass from the safety-related PLC or restore normal operation inserting the unit.

This test reveals almost 99 % of all possible Dangerous Undetected failures in the relay module.

Warning

D5290S-084 is an electrical apparatus installed into standard EN50022 T35 DIN-Rail located in Safe Area / Non Hazardous Location within the specified operating temperature limits Tamb - 40 to +60 °C. D5290S-084 must be installed, operated and maintained only by qualified personnel, in accordance to the relevant national/international installation standards, following the established installation rules.

Warning: de-energize main power source (turn off power supply voltage) and disconnect plug-in terminal blocks before opening the enclosure to avoid electrical shock when connected to live hazardous potential.

Failure to properly installation or use of the equipment may risk to damage the unit or severe personal injury.

The unit cannot be repaired by the end user and must be returned to the manufacturer or his authorized representative.

Any unauthorized modification must be avoided.

Operation

D5290S-084 relay module is suitable for the switching of safety related circuits, providing isolation between the input and output contacts.

See the previous pages for Functional Safety applications with related SIL value.

A "RELAY STATUS" yellow led lights when input is powered, showing that relay is energized.

Installation

D5290S-084 is a relay output module housed in a plastic enclosure suitable for installation on T35 DIN-Rail according to EN50022.

D5290S-084 unit can be mounted with any orientation over the entire ambient temperature range.

Electrical connection of conductors up to 2.5 mm² are accommodated by polarized plug-in removable screw terminal blocks which can be plugged in/out into a powered unit without suffering or causing any damage.

The wiring cables have to be proportionate in base to the current and the length of the cable.

On the section "Function Diagram" and enclosure side a block diagram identifies all connections.

Identify the function and location of each connection terminal using the wiring diagram on the corresponding section, as an example (n° 1 application):

Connect 110 Vdc signal lines at input terminals "1" and "2" (input terminals "3" and "4" are provided for daisy chain connection to the next module).

For Load A and its service load:

- connect positive or AC load supply line to terminals "13" and "18";
- connect SIL 3 Normally Energized (NE) Load between terminals "14" and "16";
- connect Not SIL Service Load between terminal "17" and negative or AC load supply line;
- connect terminal "15" to negative or AC load supply line.

For Load B and its service load:

- connect positive or AC load supply line to terminals "19" and "24";
- connect SIL 3 Normally Energized (NE) Load between terminals "23" and "21";
- connect Not SIL Service Load between terminal "20" and negative or AC load supply line;
- connect terminal "22" to negative or AC load supply line.

Installation and wiring must be in accordance to the relevant national or international installation standards, make sure that conductors are well isolated from each other and do not produce any unintentional connection.

Connect SPST relay contacts checking the load rating to be within the contact maximum rating (5 A 250 Vac 1250 VA, 5 A 250 Vdc 175 W (resistive load)).

To prevent relay contacts from damaging, connect an external protection (fuse or similar), chosen according to the relay breaking capacity diagram on data sheet.

The enclosure provides, according to EN60529, an IP20 minimum degree of mechanical protection (or similar to NEMA Standard 250 type 1) for indoor installation, outdoor installation requires an additional enclosure with higher degree of protection (i.e. IP54 to IP65 or NEMA type 12-13) consistent with the effective operating environment of the specific installation.

Units must be protected against dirt, dust, extreme mechanical (e.g. vibration, impact and shock) and thermal stress, and casual contacts.

If enclosure needs to be cleaned use only a cloth lightly moistened by a mixture of detergent in water.

Any penetration of cleaning liquid must be avoided to prevent damage to the unit. Any unauthorized card modification must be avoided.

Relay output contact must be connected to load non exceeding category II overvoltage limits.

Warning: de-energize main power source (turn off power supply voltage) and disconnect plug-in terminal blocks before opening the enclosure to avoid electrical shock when connected to live hazardous potential.

Start-up

Before powering the inputs of unit check that all wires are properly connected. Check conductors for exposed wires that could touch each other causing dangerous unwanted shorts.

Enabling input, the "RELAY STATUS" yellow led must be lit, all relays must be energized, so that: contacts of terminals "13"- "14" (Out S_1), "15"- "16" (Out S_2), "21"- "22" (Out S_4) and "23"- "24" (Out S_3) must be closed, while contacts of terminals "17"- "18" (Out P_1) and "19"- "20" (Out P_2) must be open.

Instead, disabling input, the "RELAY STATUS" yellow led must be turned off, all relays must be de-energized, so that: contacts of terminals "13"- "14" (Out S_1), "15"- "16" (Out S_2), "21"- "22" (Out S_4) and "23"- "24" (Out S_3) must be open, while contacts of terminals "17"- "18" (Out P_1) and "19"- "20" (Out P_2) must be closed.