



# INSTRUCTION & SAFETY MANUAL

SIL 3 Relay Output Module  
with Line and Load diagnostics  
DIN-Rail Model D1093S

## Characteristics

**General Description:** The single channel DIN Rail Relay Output D1093S is a relay module suitable for the switching of safety related circuits, up to SIL 3 level according to IEC61508:2010 Ed. 2 for high risk industries. It provides isolation between the input and output contact. D1093S provides 1 DPST contact for normally energized loads and 1 SPST contact for normally de-energized loads.

**Diagnostic:** Line breakage detection for NE and ND load conditions. Provides 1 SPST normally energized relay contact (closed) for fault indication. It de-energizes (open contact) in case of load or line fault.

**Function:** 1 relay for safety related circuits, provides isolation between input/output/fault. D1093S provides 1 DPST for NE loads and 1 SPST for ND loads.

SIL 3 Safety Function for NE load (de-energized in safe state) is available at Terminal Blocks 5-6; in this case, the safety function is met when the relay is de-energized (open contact). SIL 3 Safety Function for ND load (energized in safe state) is available at Terminal Blocks 7-8; in this case, the safety function is met when the relay is energized (closed contact).

**Signalling LEDs:** Power supply indication (green), relay status (yellow), line fault (red).

**EMC:** Fully compliant with CE marking applicable requirements.

**Functional Safety Management certification:** G.M. International is certified by TUV to conform to IEC61508:2010 part 1 clauses 5-6 for safety related systems up to and included SIL3.



## Technical Data

**Supply:** 24 Vdc nom (20 to 30 Vdc) reverse polarity protected, ripple within voltage limits  $\leq 5$  Vpp.

**Current consumption @ 24 V:** 25 mA typical.

**Power dissipation:** 0.6 W with 24 V supply voltage and fault relay energized, typical.

**Max. power consumption:** at 30 V supply voltage and fault relay energized, 0.9 W.

**Isolation (Test Voltage):** Output/Input 2.5 KV; Output/Supply 2.5 KV; Output/Fault Output 2.5 KV; Input/Supply 500 V; Input/Fault Output 500 V; Fault Output/Supply 500 V.

**Input:** 24 Vdc nom (20.4 to 27.6 Vdc) reverse polarity protected.

**Current consumption @ 24 V:** 50 mA with relay energized, typical.

**Power dissipation:** 1.2 W with 24 V input voltage and relay energized, typical.

**Max. power consumption:** at 27.6 V input voltage and relay energized, 1.5 W.

**Output:** voltage free relay contact, normally open.

**Contact material:** Ag Alloy (Cd free).

**Contact rating:** 3 A 250 Vac 750 VA, 3 A 125 Vdc 120 W (resistive load).

**Contact inrush current:** 5 A at 30 Vdc, 250 Vac.

### DC Load breaking capacity:

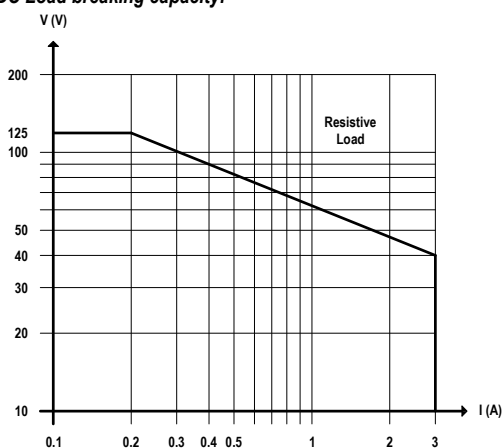

**Mechanical / Electrical life:** 50 \* 10<sup>6</sup> / 1 \* 10<sup>6</sup> operation, typical.

**Operate / Release time:** 5 / 3 ms typical.

**Bounce time NO / NC contact:** 3 ms.

**Frequency response:** 10 Hz maximum.

**Fault detection:**

**De-energized fault signal:**  $\leq 100$   $\mu$ A continuous (typical 65  $\mu$ A).

**De-energized open output detection:** load current  $\leq 30$   $\mu$ A.

**Energized open output detection:** load current  $\leq 10$  mA (no fault detection  $\geq 25$  mA).

**Fault signalling:** voltage free NE SPST relay contact (output de-energized in fault condition).

**Contact rating:** 3 A 250 Vac 750 VA, 3 A 125 Vdc 120 W (resistive load).

**Response time:** 200 ms typical.

**Compatibility:**

**CE** CE mark compliant, conforms to Directive: 2014/34/EU ATEX, 2014/30/EU EMC, 2014/35/EU LVD, 2011/65/EU RoHS.

**Environmental conditions:**

**Operating:** temperature limits  $-20$  to  $+60$   $^{\circ}$ C, relative humidity max 95 %.

**Storage:** temperature limits  $-45$  to  $+80$   $^{\circ}$ C.

**Safety Description:**



**ATEX:** II 3G Ex nAC IIC T4 Gc; **IECEx:** Ex nAC IIC T4 Gc

**FM:** NI / I / 2 / ABCD / T4, NI / I / 2 / IIC / T4

**FM-C:** NI / I / 2 / ABCD / T4, NI / I / 2 / IIC / T4

**EAC-EX:** 2Ex nA nC IIC T4 Gc X

**UKR TR n. 898:** 2ExnAnCIIC T4 X

non-incendive electrical apparatus.

$-20$   $^{\circ}$ C  $\leq$  Ta  $\leq 60$   $^{\circ}$ C.

**Approvals:**

IMQ 09 ATEX 013 X conforms to EN60079-0, EN60079-15,

IECEx IMQ 13.0011X conforms to IEC60079-0, IEC60079-15

FM & FM-C No. 3024643, 3029921C, conforms to Class 3600, 3611, 3810,

ANSI/ISA 12.12.02, ANSI/ISA 60079-0, C22.2 No.142, C22.2 No.213,

E60079-0, E60079-15,

C-IT.MH04.B.00306 conforms to GOST R IEC 60079-0, GOST R IEC 60079-15.

CLJ 16.0034 X conforms to DCTY 7113, DCTY IEC 60079-15.

TUV Certificate No. C-IS-236198-03, SIL 3 conforms to IEC61508:2010 Ed.2.

TUV Certificate No. C-IS-236198-09, SIL 3 Functional Safety Certificate conforms to IEC61508:2010 Ed.2, for Management of Functional Safety.

DNV No.A-13778 Certificates for maritime applications.

**Mounting:** T35 DIN Rail according to EN50022.

**Weight:** about 155 g.

**Connection:** by polarized plug-in disconnect screw terminal blocks to accommodate terminations up to 2.5 mm<sup>2</sup>.

**Location:** Safe Area/Non Hazardous Locations or Zone 2, Group IIC T4, Class I, Division 2, Groups A, B, C, D Temperature Code T4 and Class I, Zone 2, Group IIC, IIB, IIA T4 installation.

**Protection class:** IP 20. **Dimensions:** Width 22.5 mm, Depth 99 mm, Height 114.5 mm.

## Ordering information

Model:	D1093S
Power Bus enclosure	/B

Power Bus and DIN-Rail accessories:  
 DIN rail anchor MCHP065      DIN rail stopper MOR016  
 Terminal block male MOR017      Terminal block female MOR022

## Front Panel and Features

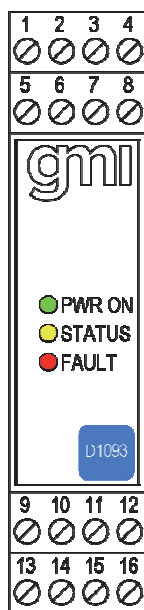

- SIL 3 according to IEC 61508:2010 Ed. 2 for Tproof = 14 / 20 years ( $\leq 10\%$  /  $>10\%$  of total SIF) with NE Load.
- SIL 3 according to IEC 61508:2010 Ed. 2 for Tproof = 9 / 20 years ( $\leq 10\%$  /  $>10\%$  of total SIF) with ND Load.
- PFDavg (1 year) 7.02 E-06, SFF 99.03 % with NE Load.
- PFDavg (1 year) 1.03 E-05, SFF 97.61 % with ND Load.
- SIL 3 Systematic capability.
- Installation in Zone 2, Division 2.
- Line and Load open diagnostic in NE and ND conditions.
- 1 DPST contact for NE load and 1 SPST contact for ND load.
- 5 A inrush current at 30 Vdc / 250 Vac.
- Three port isolation, Input/Output/Supply.
- EMC Compatibility to EN61000-6-2, EN61000-6-4, EN61326-1.
- ATEX, IECEx, FM & FM-C, EAC-EX, UKR TR n. 898, TÜV Certifications.
- Type Approval Certificate DNV for maritime applications.
- TUV Certification for SIL.
- TUV Functional Safety Certification.
- High Reliability, SMD components.
- Simplified installation using standard DIN Rail and plug-in terminal blocks.

## Terminal block connections

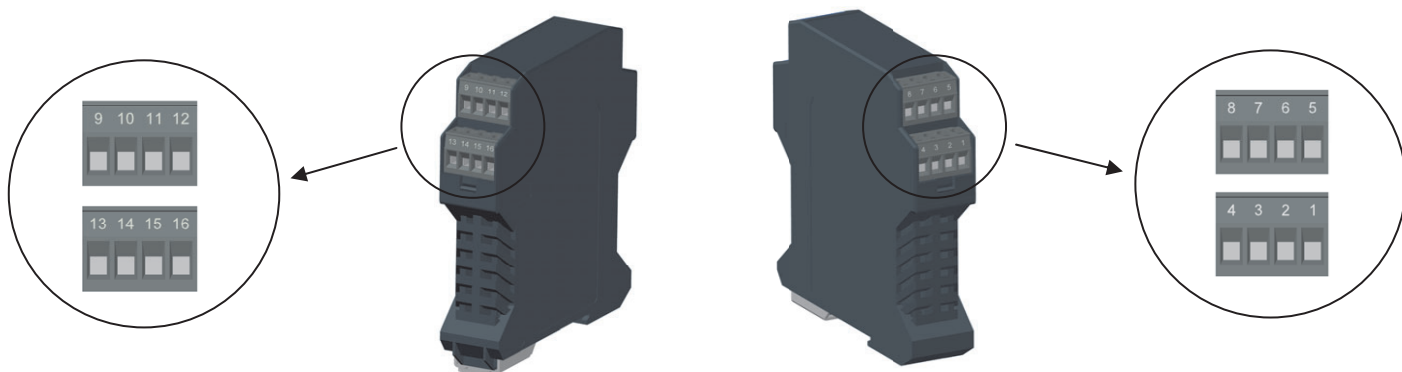

### SAFE AREA

<b>9</b>	+ Power Supply 24 Vdc
<b>10</b>	- Power Supply 24 Vdc
<b>11</b>	+ Power Supply 24 Vdc
<b>12</b>	- Power Supply 24 Vdc
<b>13</b>	+ Input Ch 1
<b>14</b>	- Input Ch 1
<b>15</b>	Fault Output
<b>16</b>	Fault Output

### SAFE AREA

<b>1</b>	+ Loop Powered DC/AC maximum 125 Vdc, 250 Vrms
<b>2</b>	- Loop Powered DC/AC maximum 125 Vdc, 250 Vrms
<b>3</b>	+ Loop Powered DC/AC maximum 125 Vdc, 250 Vrms
<b>4</b>	- Loop Powered DC/AC maximum 125 Vdc, 250 Vrms
<b>5</b>	+ Output Ch 1-A for NE Load
<b>6</b>	- Output Ch 1-A for NE Load
<b>7</b>	+ Output Ch 1-B for ND Load
<b>8</b>	- Output Ch 1-B for ND Load

## Function Diagram

SAFE AREA, ZONE 2 GROUP IIC T4,  
NON HAZARDOUS LOCATIONS, CLASS I, DIVISION 2, GROUPS A, B, C, D T-Code T4, CLASS I, ZONE 2, GROUP IIC T4

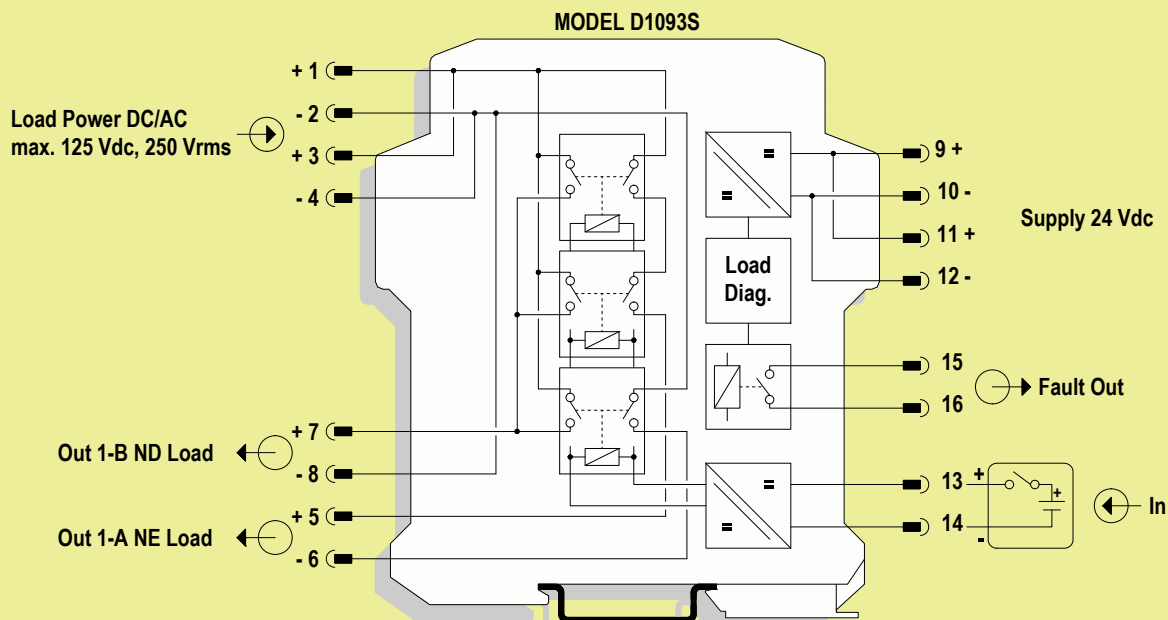

All relay contacts shown in de-energized position

To prevent relay contacts from damaging, connect an external protection (fuse or similar),  
chosen according to the relay breaking capacity diagram.

Application for D1093S - Normally Energized relay condition for NE Load

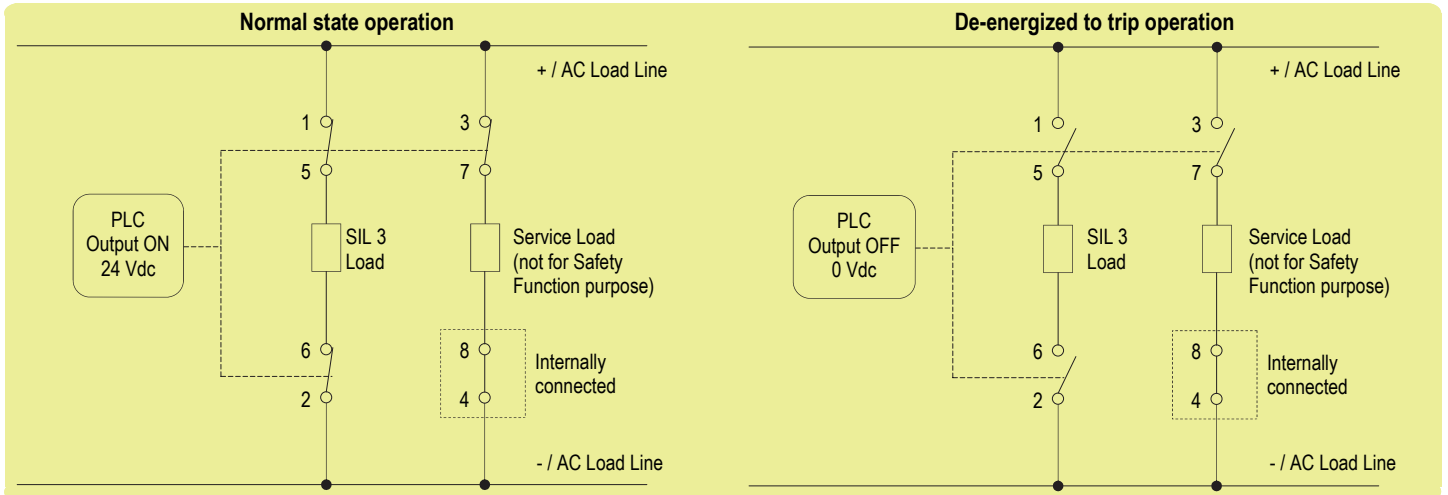

**Description:**

Input Signal from PLC/DCS is normally High (24 Vdc) and is applied to pins 13-14 in order to Normally Energize (NE) the internal relays. Input Signal from PLC/DCS is Low (0 Vdc) during "de-energize to trip" operation, in order de-energize the internal relays.

The Load is Normally Energized (NE), therefore its safe state is to be de-energized.

Disconnection of the NE Load is done on both supply lines.

Service load (connected between 7 - 8 pins) can be used to monitoring contacts 1 - 5 and 2 - 6.

The following table describes the status (open or closed) of each output contact when the input signal is High or Low.

Operation	Input Signal Pins 13-14	Pins 1 - 5	Pins 2 - 6	NE Load (SIL3) Pins 5 - 6	Pins 3 - 7	Service Load Pins 7 - 8
Normal	High (24 Vdc)	Closed	Closed	Energized	Closed	Energized
Trip	Low (0 Vdc)	Open	Open	De-Energized	Open	De-Energized

**Safety Function and Failure behavior:**

D1093S is considered to be operating in Low Demand mode, as a Type A module, having Hardware Fault Tolerance (HFT) = 0.

In this Functional Safety application, the normal state operation of relay module is energized, with NE (Normally Energized) load.

In case of alarm or request from process, the relay module is de-energized (safe state), de-energizing the load.

The failure behaviour of the relay module is described by the following definitions:

- fail-Safe State: it is defined as the output load being de-energized;
- fail Safe: this failure causes the system to go to the defined fail-safe state without a process demand;
- fail Dangerous: failure mode that does not respond to a demand from the process (i.e. being unable to go to the defined fail-safe state), so that the output load remains energized.
- fail "No effect": failure mode of a component that plays a part in implementing the safety function but is neither a safe failure nor a dangerous failure; When calculating the SFF this failure mode is not taken into account.
- fail "Not part": failure mode of a component which is not part of the safety function but part of the circuit diagram and is listed for completeness; When calculating the SFF this failure mode is not taken into account.

Failure rate data: taken from Siemens Standard SN29500.

**Failure rate table:**

Failure category	Failure rates (FIT)
$\lambda_{dd}$ = Total Dangerous Detected failures	0.00
$\lambda_{du}$ = Total Dangerous Undetected failures	1.60
$\lambda_{sd}$ = Total Safe Detected failures	0.00
$\lambda_{su}$ = Total Safe Undetected failures	162.99
$\lambda_{tot\ safe}$ = Total Failure Rate (Safety Function) = $\lambda_{dd} + \lambda_{du} + \lambda_{sd} + \lambda_{su}$	164.59
MTBF (Safety Function, single channel) = $(1 / \lambda_{tot\ safe}) + MTTR$	693 years
$\lambda_{no\ effect}$ = "No Effect" failures	165.61
$\lambda_{not\ part}$ = "Not Part" failures	301.40
$\lambda_{tot\ device}$ = Total Failure Rate (Device) = $\lambda_{tot\ safe} + \lambda_{no\ effect} + \lambda_{not\ part}$	631.60
MTBF (Device, single channel) = $(1 / \lambda_{tot\ device}) + MTTR$	180 years

**Failure rates table according to IEC 61508:2010 Ed.2 :**

$\lambda_{sd}$	$\lambda_{su}$	$\lambda_{dd}$	$\lambda_{du}$	SFF
0.00 FIT	162.99 FIT	0.00 FIT	1.60 FIT	99.03%

**PFDavg vs T[Proof] table** (assuming Proof Test coverage of 90%), with determination of SIL supposing module contributes ≤10% of total SIF dangerous failures:

T[Proof] = 1 year	T[Proof] = 14 years
PFDavg = 7.02 E-06 - Valid for SIL 3	PFDavg = 9.83 E-05 - Valid for SIL 3

**PFDavg vs T[Proof] table** (assuming Proof Test coverage of 90%), with determination of SIL supposing module contributes >10% of total SIF dangerous failures:

T[Proof] = 20 years
PFDavg = 1.40 E-04 - Valid for SIL 3

Systematic capability SIL 3.

Application for D1093S - Normally De-energized relay condition for ND Load

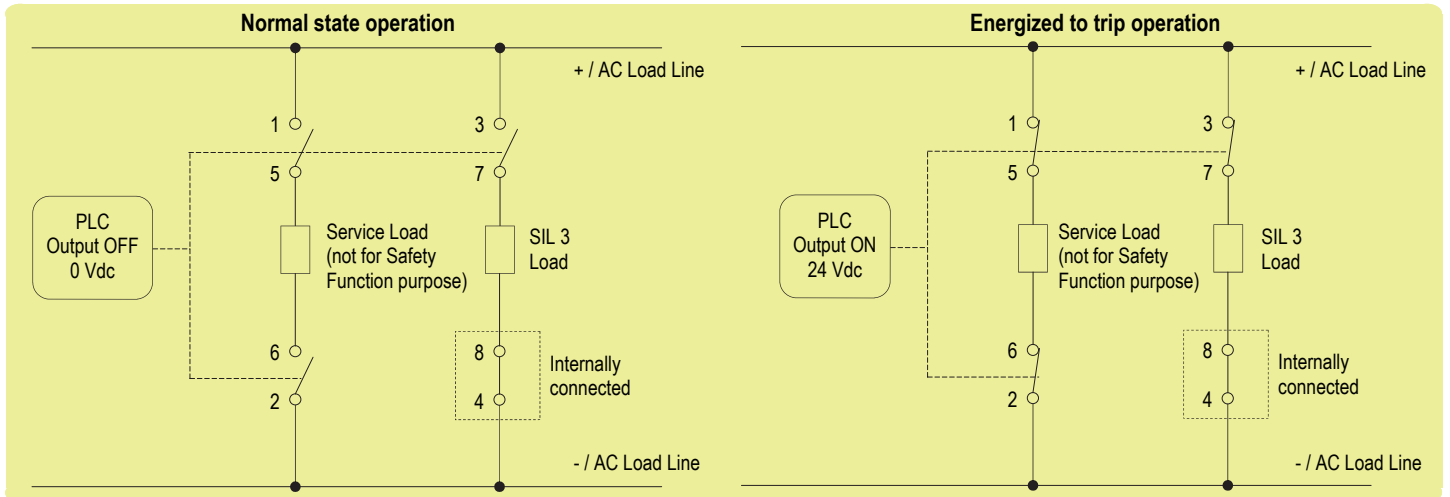

**Description:**

Input Signal from PLC/DCS is normally Low (0 Vdc) and is applied to pins 13-14 in order to Normally De-energize (ND) the internal relays. Input Signal from PLC/DCS is High (24 Vdc) during "Energize to trip" operation, in order to energize the internal relays.

The Load is Normally De-energized (ND), therefore its safe state is to be energized. Disconnection of the ND Load is done on only one supply line.

Service load (connected between 5 - 6 pins) can be used to monitoring contacts 3 - 7.

The following table describes the status (open or closed) of each output contact when the input signal is High or Low.

Operation	Input Signal Pins 13-14	Pins 1 - 5	Pins 2 - 6	Service Load Pins 5 - 6	Pins 3 - 7	ND Load (SIL3) Pins 7 - 8
Normal	Low (0 Vdc)	Open	Open	De-Energized	Open	De-Energized
Trip	High (24 Vdc)	Closed	Closed	Energized	Closed	Energized

**Safety Function and Failure behavior:**

D1093S is considered to be operating in Low Demand mode, as a Type A module, having Hardware Fault Tolerance (HFT) = 0.

In this Functional Safety application, the normal state operation of relay module is de-energized, with ND (Normally De-energized) load.

In case of alarm or request from process, the relay module is energized (safe state), energizing the load.

The failure behaviour of the relay module is described by the following definitions:

- fail-Safe State: it is defined as the output load being energized;
- fail Safe: this failure causes the system to go to the defined fail-safe state without a process demand;
- fail Dangerous: failure mode that does not respond to a demand from the process (i.e. being unable to go to the defined fail-safe state), so that the output load remains de-energized.
- fail "No effect": failure mode of a component that plays a part in implementing the safety function but is neither a safe failure nor a dangerous failure; When calculating the SFF this failure mode is not taken into account.
- fail "Not part": failure mode of a component which is not part of the safety function but part of the circuit diagram and is listed for completeness; When calculating the SFF this failure mode is not taken into account.

Failure rate data: taken from Siemens Standard SN29500.

**Failure rate table:**

Failure category	Failure rates (FIT)
$\lambda_{dd}$ = Total Dangerous Detected failures	0.00
$\lambda_{du}$ = Total Dangerous Undetected failures	2.35
$\lambda_{sd}$ = Total Safe Detected failures	0.00
$\lambda_{su}$ = Total Safe Undetected failures	96.00
$\lambda_{tot\ safe}$ = Total Failure Rate (Safety Function) = $\lambda_{dd} + \lambda_{du} + \lambda_{sd} + \lambda_{su}$	98.35
MTBF (Safety Function, single channel) = $(1 / \lambda_{tot\ safe}) + MTTR$	1160 years
$\lambda_{no\ effect}$ = "No Effect" failures	231.85
$\lambda_{not\ part}$ = "Not Part" failures	301.40
$\lambda_{tot\ device}$ = Total Failure Rate (Device) = $\lambda_{tot\ safe} + \lambda_{no\ effect} + \lambda_{not\ part}$	631.60
MTBF (Device, single channel) = $(1 / \lambda_{tot\ device}) + MTTR$	180 years

**Failure rates table according to IEC 61508:2010 Ed.2 :**

$\lambda_{sd}$	$\lambda_{su}$	$\lambda_{dd}$	$\lambda_{du}$	SFF
0.00 FIT	96.00 FIT	0.00 FIT	2.35 FIT	97.61%

**PFDavg vs T[Proof] table** (assuming Proof Test coverage of 90%), with determination of SIL supposing module contributes  $\leq 10\%$  of total SIF dangerous failures:

T[Proof] = 1 year	T[Proof] = 9 years
PFDavg = 1.03 E-05 - Valid for SIL 3	PFDavg = 9.27 E-05 - Valid for SIL 3

**PFDavg vs T[Proof] table** (assuming Proof Test coverage of 90%), with determination of SIL supposing module contributes  $> 10\%$  of total SIF dangerous failures:

T[Proof] = 20 years
PFDavg = 2.06 E-04 - Valid for SIL 2

Systematic capability SIL 3.

## Testing procedure at T-proof

The proof test shall be performed to reveal dangerous faults which are undetected by diagnostic. This means that it is necessary to specify how dangerous undetected faults, which have been noted during the FMECA, can be revealed during proof test. Proof test consists of the following steps:

Steps	Action
1	Bypass the safety-related PLC or take other appropriate action to avoid a false trip.
2	Supply diagnostic circuit (terminals "9-11" and "10-12") and watch LEDs or fault output for verification. For D1093S single channel, verify input-output functionality for two different application: <ol style="list-style-type: none"> <li>normally energized (NE) loads (terminals "5" and "6"): supply input channel (terminals "13" &amp; "14") and verify that load is energized; then shutdown input channel and verify that load is de-energized (safe state). In both cases, if the load is disconnected (fault condition), the fault red LED must be lit and the fault output must be de-energized .</li> <li>normally de-energized (ND) loads (terminals "7" &amp; "8"): supply input channel (terminals "13" &amp; "14") and verify that load is energized (safe state); then shutdown input channel and verify that load is de-energized. In both cases, if load is disconnected (fault condition), the fault red LED must be lit and the fault output must be de-energized.</li> </ol>
3	Remove the bypass from the safety-related PLC or restore normal operation.

This test reveals almost 90 % of all possible Dangerous Undetected failures in the relay module.

## Warning

D1093 is an isolated electrical apparatus installed into standard EN50022 T35 DIN Rail located in Safe Area/Non Hazardous Locations or Zone 2, Group IIC, Temperature Classification T4, Class I, Division 2, Groups A, B, C, D, Temperature Code T4 and Class I, Zone 2, Group IIC, IIB, IIA Temperature Code T4 Hazardous Area/Hazardous Locations (according to EN/IEC60079-15, FM Class No. 3611, CSA-C22.2 No. 213-M1987, CSA-E60079-15) within the specified operating temperature limits Tamb -20 to +60 °C, and connected to equipment with a maximum limit for AC power supply of 250 Vrms.

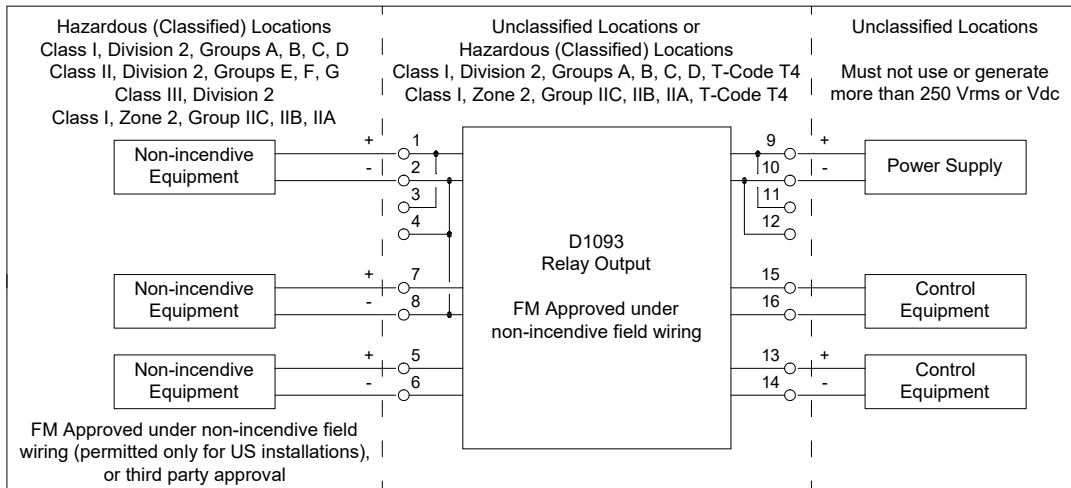

Non-incendive field wiring is not recognized by the Canadian Electrical Code, installation is permitted in the US only. For installation of the unit in a Class I, Division 2 or Class I, Zone 2 location, the wiring between the control equipment and the D1093 electrical apparatus shall be accomplished via conduit connections or another acceptable Division 2, Zone 2 wiring method according to the NEC and the CEC. Not to be connected to control equipment that uses or generates more than 250 Vrms or Vdc with respect to earth ground. D1093 must be installed, operated and maintained only by qualified personnel, in accordance to the relevant national/international installation standards (e.g. IEC/EN60079-14 Electrical apparatus for explosive gas atmospheres - Part 14: Electrical installations in hazardous areas (other than mines), BS 5345 Pt4, VDE 165, ANSI/ISA RP12.06.01 Installation of Intrinsically Safe System for Hazardous (Classified) Locations, National Electrical Code NEC ANSI/NFPA 70 Section 504 and 505, Canadian Electrical Code CEC) following the established installation rules. De-energize power source (turn off power supply voltage) before plug or unplug the terminal blocks when installed in Hazardous Area/ Hazardous Locations or unless area is known to be nonhazardous.

**Warning: substitution of components may impair Intrinsic Safety and suitability for Division 2, Zone 2. Warning: de-energize main power source (turn off power supply voltage) and disconnect plug-in terminal blocks before opening the enclosure to avoid electrical shock when connected to live hazardous potential.**

**Explosion Hazard: to prevent ignition of flammable or combustible atmospheres, disconnect power before servicing or unless area is known to be nonhazardous.**

Failure to properly installation or use of the equipment may risk to damage the unit or severe personal injury.

The unit cannot be repaired by the end user and must be returned to the manufacturer or his authorized representative. Any unauthorized modification must be avoided.

## Operation

D1093 relay module is suitable for the switching of safety related circuits, providing isolation between the input and output contacts.

D1093 provides 1 DPST contact for normally energized (NE) loads and 1 SPST contact for normally de-energized (ND) loads. In addition, there is a diagnostic circuit for line breakage and load operating anomaly detection in both NE and ND load conditions.

The fault indication is provided by a SPST normally energized relay (normally close contact), which is de-energized (open contact) in case of line or load fault.

The fault output, diagnostic circuit, input and output contacts are isolated each other. In fact, the diagnostic circuit is supplied from independent external power supply.

A "POWER ON" green led lights when supply power is present. A "RELAY STATUS" yellow led lights when input is powered, showing that relay is energized and relay output contacts are closed. A "LINE FAULT" red led lights when line breakage and load operating anomaly is detected.

## Installation

D1093 is a relay output modules housed in a plastic enclosure suitable for installation on T35 DIN Rail according to EN50022. D1093 unit can be mounted with any orientation over the entire ambient temperature range, see section "Installation in Cabinet" and "Installation of Electronic Equipments in Cabinet" Instruction Manual D1000 series for detailed instructions. Electrical connection of conductors up to 2.5 mm<sup>2</sup> are accommodated by polarized plug-in removable screw terminal blocks which can be plugged in/out into a powered unit without suffering or causing any damage (**for Zone 2 or Division 2 installations check the area to be nonhazardous before servicing**). The wiring cables have to be proportionate in base to the current and the length of the cable. On the section "Function Diagram" and enclosure side a block diagram identifies all connections.

Identify the function and location of each connection terminal using the wiring diagram on the corresponding section, as an example:

Connect 24 Vdc power supply positive at terminals "9" (or "11") and negative at terminals "10" (or "12"), to drive the diagnostic circuits. Connect positive input at terminal "13" and negative input at "14". Connect fault indication relay output contact at terminal "15" and "16". In case of NE loads, connect the NE loads at positive terminal "5" and negative terminal "6". In case of ND loads, connect the ND loads at positive terminal "7" and negative terminal "8". If load requires DC power supply, connect supply line positive at terminals "1" (or "3") and negative at terminals "2" (or "4"). If load requires AC power supply, connect AC lines at terminals "1" (or "3") and "2" (or "4").

Installation and wiring must be in accordance to the relevant national or international installation standards (e.g. IEC/EN60079-14 Electrical apparatus for explosive gas atmospheres - Part 14: Electrical installations in hazardous areas (other than mines), BS 5345 Pt4, VDE 165, ANSI/ISA RP12.06.01 Installation of Intrinsically Safe System for Hazardous (Classified) Locations, National Electrical Code NEC ANSI/NFPA 70 Section 504 and 505, and the Canadian Electrical Code CEC), make sure that conductors are well isolated from each other and do not produce any unintentional connection.

Connect output relay contacts checking the load rating to be within the contact maximum rating (3 A, 250 Vac or 125 Vdc, 750 VA 120 W resistive load).

**If necessary, to prevent relay contacts from damaging, an external protection (fuse or similar) should be connected.**

**A suitable protection must be chosen according to the relay breaking capacity diagram on data sheet.**

Connect fault indication relay contacts checking the load rating to be within the contact maximum rating (3 A, 250 Vac or 125 Vdc, 750 VA 120 W resistive load).

The enclosure provides, according to EN60529, an IP20 minimum degree of mechanical protection (or similar to NEMA Standard 250 type 1) for indoor installation, outdoor installation requires an additional enclosure with higher degree of protection (i.e. IP54 to IP65 or NEMA type 12-13) consistent with the effective operating environment of the specific installation. Units must be protected against dirt, dust, extreme mechanical (e.g. vibration, impact and shock) and thermal stress, and casual contacts.

If enclosure needs to be cleaned use only a cloth lightly moistened by a mixture of detergent in water.

**Electrostatic Hazard: to avoid electrostatic hazard, the enclosure of D1093 must be cleaned only with a damp or antistatic cloth.**

Any penetration of cleaning liquid must be avoided to prevent damage to the unit. Any unauthorized card modification must be avoided.

Relay output contact must be connected to loads non exceeding category I, pollution degree I overvoltage limits.

**Warning: de-energize main power source (turn off power supply voltage) and disconnect plug-in terminal blocks before opening the enclosure to avoid electrical shock when connected to live hazardous potential.**

## Start-up

Before powering the inputs of unit check that all wires are properly connected, also verifying their polarity. Check conductors for exposed wires that could touch each other causing dangerous unwanted shorts. Turn on power supply for diagnostic circuits, the "power on" green led must be lit. Then enabling the input of channel, the "RELAY STATUS" yellow led must be lit and load circuit must be energized because relay output contact is closed. Indeed, disabling the input of channel, the "RELAY STATUS" yellow led must be turned off and load circuit must be de-energized because relay output contact is open. The "LINE FAULT" red led could only be lit when line breakage or load operating anomaly is detected by internal diagnostic circuits, imposing to de-energize the SPST relay (open its contact) for fault indication.