



INSTRUCTION & SAFETY MANUAL

SIL 3 Relay Output Module DIN-Rail Models D1092S-069, D1092D-069

Characteristics

General Description: The single and dual channel DIN Rail Relay Output, D1092S-069 and D1092D-069 are relay modules suitable for the switching of safety related circuits, up to SIL 3 level according to IEC61508:2010 Ed. 2, for high risk industries. Isolation is provided between input and output contacts, and between the two channels of D1092D-069.

Function: 1 or 2 totally independent and isolated relays for safety related circuits.

D1092S-069: SIL 3 Safety Function for NE relay (de-energized in safe state) is available at Terminal Blocks 1-2; in this case, the safety function is met when the relay is de-energized (open contact). SIL 3 Safety Function for NE relay (de-energized in safe state) is available at Terminal Blocks 3-4; in this case, the safety function is met when the relay is de-energized (closed contact).

D1092D-069:

SIL 3 Safety Function NE relay (de-energized in safe state) is available at Terminal Blocks 1-2 and Terminal Blocks 5-6; in this case, the safety function is met when the relays are de-energized (open contacts). SIL 3 Safety Function for NE relay (de-energized in safe state) is available at Terminal Blocks 3-4 and Terminal Blocks 7-8; in this case the safety function is met when the relays are de-energized (closed contacts).

Signalling LEDs: Relay status (yellow).

EMC: Fully compliant with CE marking applicable requirements.

Functional Safety Management certification: G.M. International is certified by TUV to conform to IEC61508:2010 part 1 clauses 5-6 for safety related systems up to and included SIL3.



Technical Data

Input: 24 Vdc nom (20.4 to 27.6 Vdc) reverse polarity protected, ripple within voltage limits ≤ 5 Vpp.

Current consumption @ 24 V: 50 mA for each channel with relay energized, typical (100 mA for 2 channels D1092D-069 when used as duplicator 1 input / 2 outputs).

Power dissipation: 1.2 W for each channel with 24 V input voltage and relay energized, typical (2.4 W for 2 channels D1092D-069 when used as duplicator).

Max. power consumption: at 27.6 V input voltage and relay energized, 1.5 W for each channel (3.0 W for 2 channels D1092D-069 when used as duplicator).

Isolation (Test Voltage): Input/Output 2.5 KV; Input/Input 500 V; Output/Output 2.5 KV; Output A/Output B 1.5 KV.

Output: voltage free SPST NO + SPST NC relay contact.

Contact material: Ag Alloy (Cd free).

Contact rating: 3 A 250 Vac 750 VA, 3 A 125 Vdc 120 W (resistive load).

Contact inrush current: 5 A at 30 Vdc, 250 Vac.

DC Load breaking capacity:

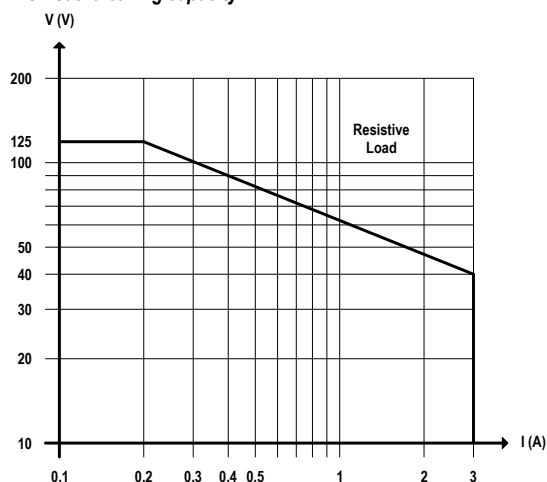

Mechanical / Electrical life: $50 * 10^6 / 1 * 10^5$ operation, typical.

Operate / Release time: 5 / 3 ms typical.

Bounce time NO / NC contact: 3 ms.

Frequency response: 10 Hz maximum.

Compatibility:



CE mark compliant, conforms to Directive: 2014/34/EU ATEX, 2014/30/EU EMC, 2014/35/EU LVD, 2011/65/EU RoHS.

Environmental conditions:

Operating: temperature limits -20 to $+60$ °C, relative humidity max 95 %.

Storage: temperature limits -45 to $+80$ °C.

Safety Description:



ATEX: II 3G Ex nAC IIC T4 Gc; **IECEx:** Ex nAC IIC T4 Gc

FM: NI / I / 2 / ABCD / T4, NI / I / 2 / IIC / T4

FM-C: NI / I / 2 / ABCD / T4, NI / I / 2 / IIC / T4

EAC-EX: 2Ex nA nC IIC T4 Gc X

UKR TR n. 898: 2ExnAnCIIC T4 X

non-incendive electrical apparatus.

-20 °C \leq Ta \leq 60 °C.

Approvals:

IMQ 09 ATEX 013 X conforms to EN60079-0, EN60079-15,

IECEx IMQ 13.0011X conforms to IEC60079-0, IEC60079-15

FM & FM-C No. 3024643, 3029921C, conforms to Class 3600, 3611, 3810, ANSI/ISA 12.12.02, ANSI/ISA 60079-0, C22.2 No.142, C22.2 No.213, E60079-0, E60079-15.

C-IT.MH04.B.00306 conforms to GOST R IEC 60079-0, GOST R IEC 60079-15.

CLJ 16.0034 X conforms to DCTY 7113, DCTY IEC 60079-15.

TÜV Certificate No. C-IS-236198-03, SIL 3 conforms to IEC61508:2010 Ed.2.

TÜV Certificate No. C-IS-236198-09, SIL 3 Functional Safety Certificate conforms to IEC61508:2010 Ed.2, for Management of Functional Safety.

DNV No.A-13778 Certificates for maritime applications.

Mounting: T35 DIN Rail according to EN50022.

Weight: about 145 g D1092D-069, 110 g D1092S-069.

Connection: by polarized plug-in disconnect screw terminal blocks to accommodate terminations up to 2.5 mm².

Location: Safe Area/Non Hazardous Locations or Zone 2, Group IIC T4, Class I, Division 2, Groups A, B, C, D Temperature Code T4 and Class I, Zone 2, Group IIC, IIB, IIA T4 installation.

Protection class: IP 20.

Dimensions: Width 22.5 mm, Depth 99 mm, Height 114.5 mm.

Ordering information

Model:	D1092	
1 channel		S-069
2 channels		D-069

DIN-Rail accessories:
DIN rail stopper MOR016

Front Panel and Features

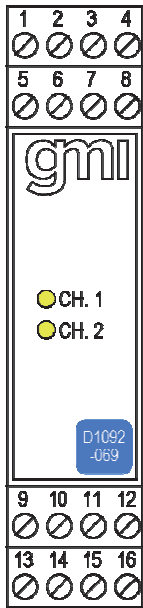

- SIL 3 according to IEC 61508:2010 Ed. 2 for Tproof = 14 / 20 years ($\leq 10\%$ / $> 10\%$ of total SIF) for NE Relay (1 SPST NO or NC contact).
- PFDavg (1 year) 7.02 E-06, SFF 98.99 %.
- SIL 3 Systematic capability.
- Installation in Zone 2, Division 2.
- 2 fully independent channels.
- 1 SPST NO contact and 1 SPST NC contact for each channel.
- 5 A inrush current at 30 Vdc / 250 Vac.
- Input/Output isolation.
- EMC Compatibility to EN61000-6-2, EN61000-6-4, EN61326-1.
- ATEX, IECEx, FM & FM-C, EAC-EX, UKR TR n. 898, TÜV Certifications.
- Type Approval Certificate DNV for maritime applications.
- TÜV Certification for SIL.
- TÜV Functional Safety Certification.
- High Reliability, SMD components.
- High Density, two channels per unit.
- Simplified installation using standard DIN Rail and plug-in terminal blocks.

Terminal block connections

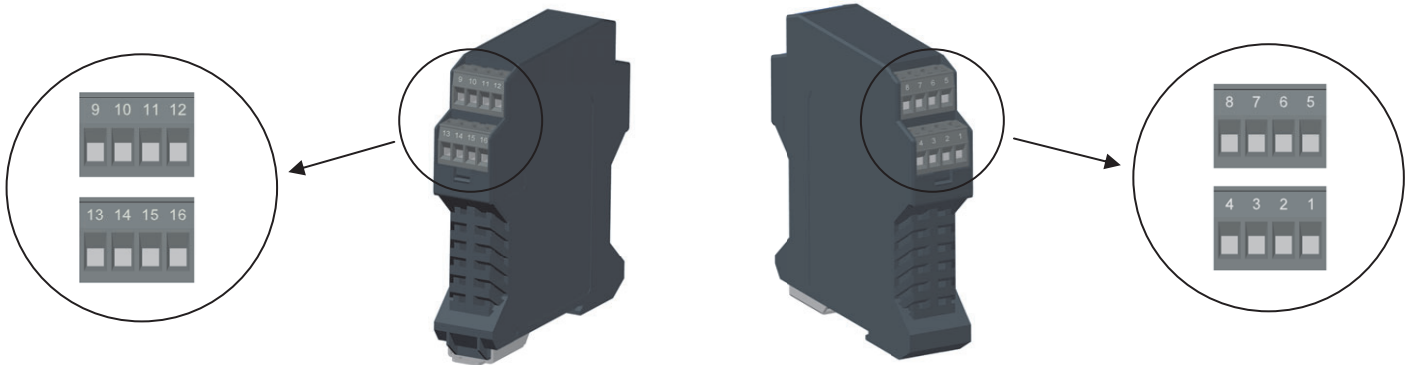

SAFE AREA

9	+ Input Ch 1 connected to terminal 13
10	+ Input Ch 2 connected to terminal 15
11	- Input Ch 1 connected to terminal 14
12	- Input Ch 2 connected to terminal 16
13	+ Input Ch 1
14	- Input Ch 1
15	+ Input Ch 2
16	- Input Ch 2

SAFE AREA

1	Output Ch 1-A (NO contact)
2	Output Ch 1-A (NO contact)
3	Output Ch 1-B (NC contact)
4	Output Ch 1-B (NC contact)
5	Output Ch 2-A (NO contact)
6	Output Ch 2-A (NO contact)
7	Output Ch 2-B (NC contact)
8	Output Ch 2-B (NC contact)

Function Diagram

SAFE AREA, ZONE 2 GROUP IIC T4,
NON HAZARDOUS LOCATIONS, CLASS I, DIVISION 2, GROUPS A, B, C, D T-Code T4, CLASS I, ZONE 2, GROUP IIC T4

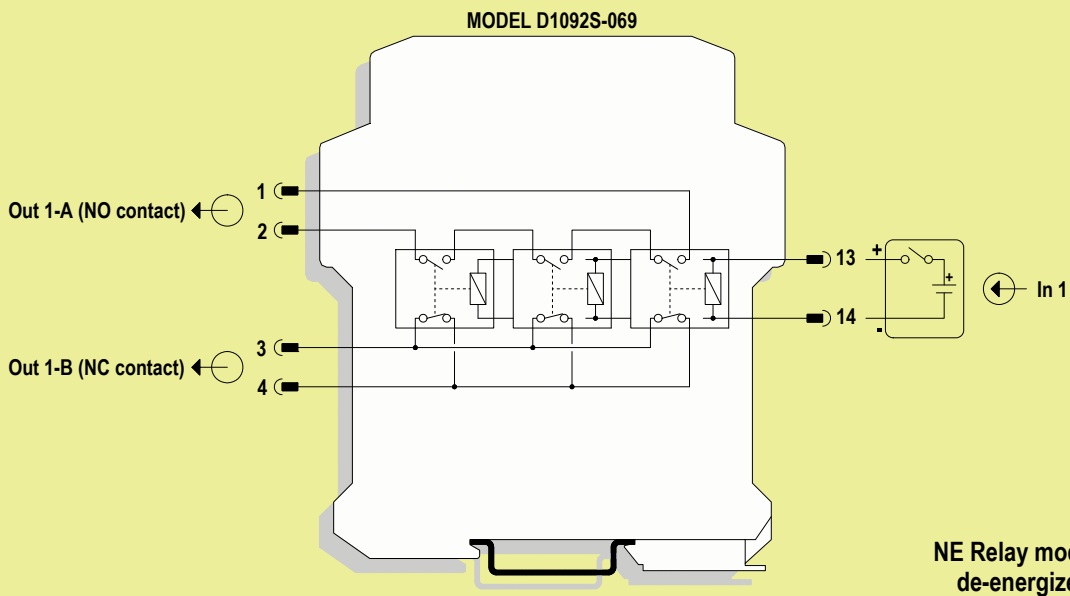
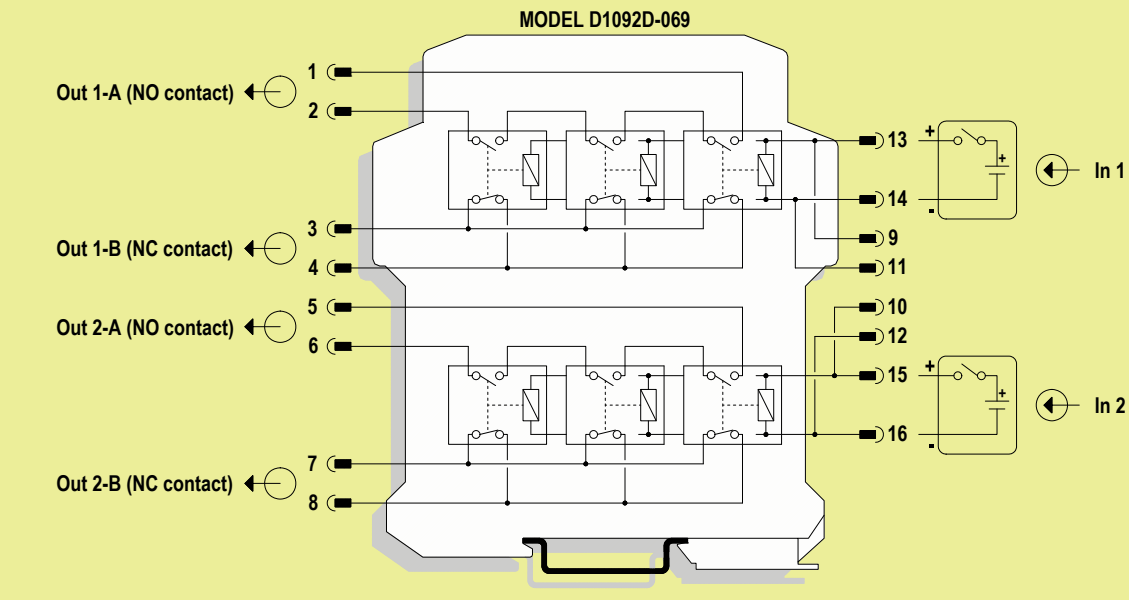

NE Relay module shown in
de-energized (safe) state

Application for D1092S-069 and D1092D-069 - Normally Energized (NE) relay condition for SPST NO output contacts

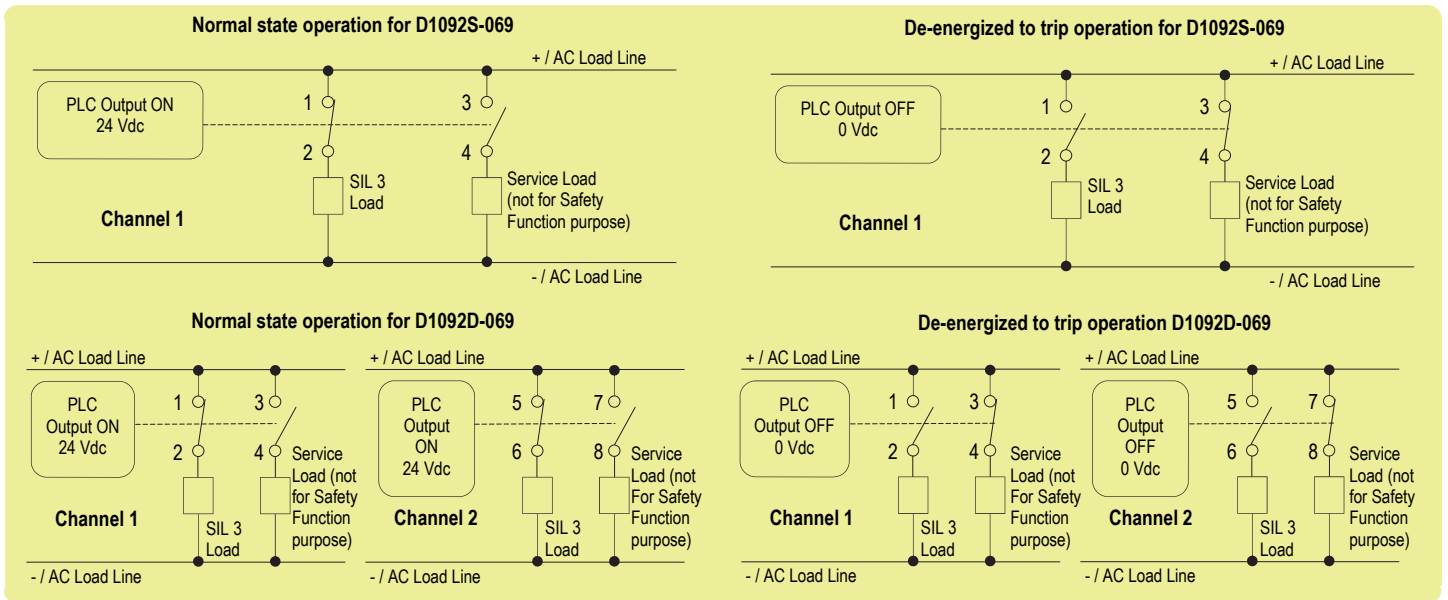

Description:

Input Signal from PLC/DCS is normally High (24 Vdc) and is applied to pins 13-14 or 9 - 11 (D1092S-069 or 1st ch. of D1092D-069) and pins 15-16 or 10 - 12 (2nd ch. of D1092D-069) in order to Normally Energize (NE) the internal relays.
 Input Signal from PLC/DCS is Low (0 Vdc) during "de-energize to trip" operation, in order de-energize the internal relays.
 The Load is Normally Energized (NE), therefore its safe state is to be de-energized.
 Disconnection of the NE Load is done on only one supply line.
 Service load connected in series to 3 – 4 contact can be used to monitoring 1 - 2 contact. Service load connected in series to 7 – 8 contact can be used to monitoring 5 - 6 contact.
 The following table describes the status (open or closed) of each output contact when the input signal is High or Low.

Operation	Input Signal Pins 13-14 or 9 -11 (for ch.1) Pins 15-16 or 10 -12 (for ch.2)	Pins 1 - 2	NE Load (SIL3) For ch. 1	Pins 3 - 4	Service Load to monitor ch.1 (inverse function)	Pins 5 - 6	NE Load (SIL3) For ch. 2 Only for D1092D-069	Pins 7 - 8	Service Load to monitor ch.2 (inverse function)
Normal	High (24 Vdc)	Closed	Energized	Open	De-energized	Closed	Energized	Open	De-energized
Trip	Low (0 Vdc)	Open	De-energized	Closed	Energized	Open	De-energized	Closed	Energized

Safety Function and Failure behavior:

D1092S-069 and D1092D-069 are considered to be operating in Low Demand mode, as a Type A module, having Hardware Fault Tolerance (HFT) = 0.
 In this Functional Safety application, the normal state operation of relay module is energized, with NE (Normally Energized) load for functional safety purpose.
 In case of alarm or request from process, the relay module is de-energized (safe state), de-energizing the load for functional safety purpose.
 The failure behaviour of the relay module is described by the following definitions:

- fail-Safe State: it is defined as the output load being de-energized, so that the NO contacts remain open;
- fail Safe: this failure causes the system to go to the defined fail-safe state without a process demand;
- fail Dangerous: failure mode that does not respond to a demand from the process (i.e. being unable to go to the defined fail-safe state), so that the output load remains energized and the NO contacts are closed.
- fail "No effect": failure mode of a component that plays a part in implementing the safety function but that is neither a safe failure nor a dangerous failure. When calculating the SFF, this failure mode is not taken into account;
- fail "Not part": failure mode of a component which is not part of the safety function but part of the circuit diagram and is listed for completeness. When calculating the SFF this failure mode is not taken into account.

Failure rate date: taken from Siemens Standard SN29500.

Failure rate table:

Failure category	Failure rates (FIT)
λ_{dd} = Total Dangerous Detected failures	0.00
λ_{du} = Total Dangerous Undetected failures	1.60
λ_{sd} = Total Safe Detected failures	0.00
λ_{su} = Total Safe Undetected failures	156.99
$\lambda_{tot\ safe}$ = Total Failure Rate (Safety Function) = $\lambda_{dd} + \lambda_{du} + \lambda_{sd} + \lambda_{su}$	158.59
MTBF (Safety Function, single channel) = $(1 / \lambda_{tot\ safe}) + MTTR$	719 years
$\lambda_{no\ effect}$ = "No Effect" failures	128.01
$\lambda_{not\ part}$ = "Not Part" failures	0.00
$\lambda_{tot\ device}$ = Total Failure Rate (Device) = $\lambda_{tot\ safe} + \lambda_{no\ effect} + \lambda_{not\ part}$	286.60
MTBF (Device, single channel) = $(1 / \lambda_{tot\ device}) + MTTR$	398 years

Failure rates table according to IEC 61508:2010 Ed.2 :

λ_{sd}	λ_{su}	λ_{dd}	λ_{du}	SFF
0.00 FIT	156.99 FIT	0.00 FIT	1.60 FIT	98.99%

PFDavg vs T[Proof] table (assuming Proof Test coverage of 99%), with determination of SIL supposing module contributes ≤10% of total SIF dangerous failures:

T[Proof] = 1 year	T[Proof] = 14 years
PFDavg = 7.02 E-06 - Valid for SIL 3	PFDavg = 9.83 E-05 - Valid for SIL 3

PFDavg vs T[Proof] table (assuming Proof Test coverage of 99%), with determination of SIL supposing module contributes >10% of total SIF dangerous failures:

T[Proof] = 20 years
PFDavg = 1.40 E-04 - Valid for SIL 3

Systematic capability SIL 3.

Application for D1092S-069 and D1092D-069 - Normally Energized (NE) relay condition for SPST NC output contacts

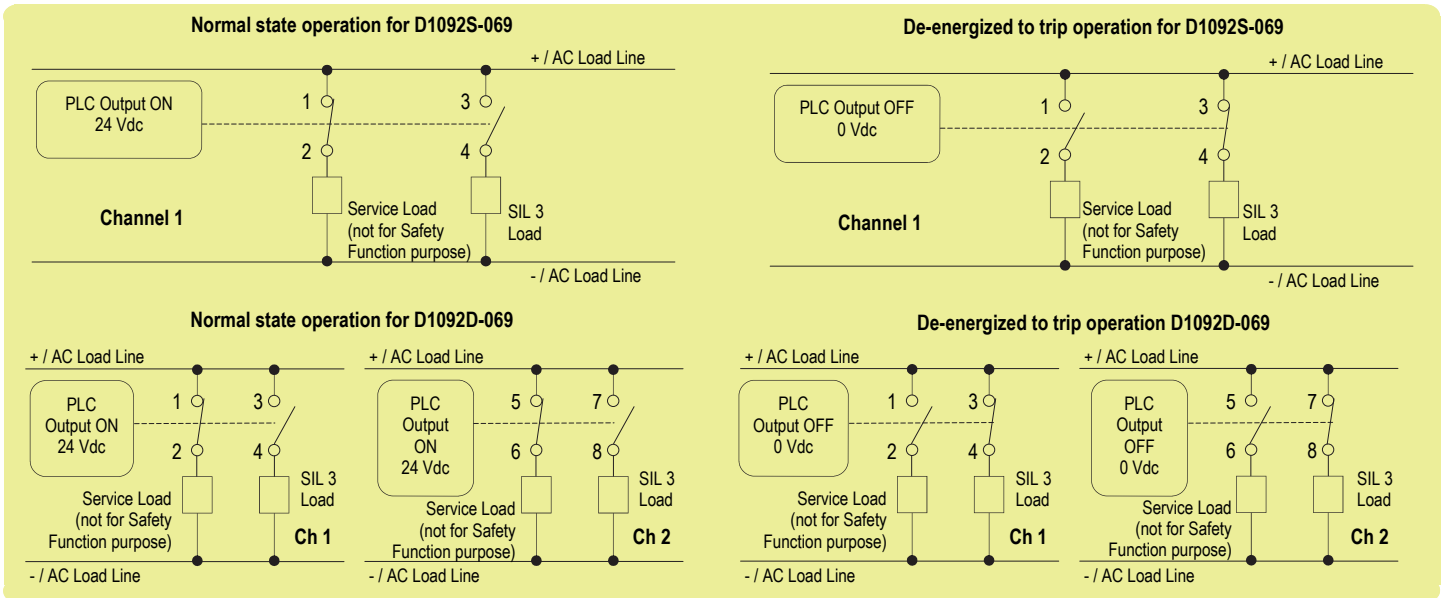

Description:

Input Signal from PLC/DCS is normally High (24 Vdc) and is applied to pins 13-14 or 9 - 11 (D1092S-069 or 1st ch. of D1092D-069) and pins 15-16 or 10 - 12 (2nd ch. of D1092D-069) in order to Normally Energize (NE) the internal relays.
 Input Signal from PLC/DCS is Low (0 Vdc) during "de-energize to trip" operation, in order de-energize the internal relays.
 The Load is Normally De-energized (ND), therefore its safe state is to be energized.
 Disconnection of the ND Load is done on only one supply line.
 Service load connected in series to 1 – 2 contact can be used to monitoring 3 - 4 contact. Service load connected in series to 5 – 6 contact can be used to monitoring 7 - 8 contact.
 The following table describes the status (open or closed) of each output contact when the input signal is High or Low.

Operation	Input Signal		Pins 3 - 4	ND Load (SIL3) For ch. 1	Pins 1 - 2	Service Load to monitor ch.1 (inverse function)	Pins 7 - 8	ND Load (SIL3) For ch. 2 Only for D1092D-069	Pins 5 - 6	Service Load to monitor ch.2 (inverse function)
	Pins 13-14 or 9 –11 (for ch.1)	Pins 15 -16 or 10 –12 (for ch.2)								
Normal	High (24 Vdc)		Open	De-energized	Closed	Energized	Open	De-energized	Closed	Energized
Trip	Low (0 Vdc)		Closed	Energized	Open	De-energized	Closed	Energized	Open	De-Energized

Safety Function and Failure behavior:

D1092S-069 and D1092D-069 are considered to be operating in Low Demand mode, as a Type A module, having Hardware Fault Tolerance (HFT) = 0.
 In this Functional Safety application, the normal state operation of relay module is energized, with ND (Normally De-energized) load for functional safety purpose.
 In case of alarm or request from process, the relay module is de-energized (safe state), energizing the load for functional safety purpose.

The failure behaviour of the relay module is described by the following definitions:

- fail-Safe State: it is defined as the output load being energized, so that the NC contacts remain closed;
- fail Safe: this failure causes the system to go to the defined fail-safe state without a process demand;
- fail Dangerous: failure mode that does not respond to a demand from the process (i.e. being unable to go to the defined fail-safe state), so that the output load remains de-energized and the NC contacts are open.
- fail "No effect": failure mode of a component that plays a part in implementing the safety function but that is neither a safe failure nor a dangerous failure. When calculating the SFF, this failure mode is not taken into account;
- fail "Not part": failure mode of a component which is not part of the safety function but part of the circuit diagram and is listed for completeness. When calculating the SFF this failure mode is not taken into account.

Failure rate date: taken from Siemens Standard SN29500.

Failure rate table:

Failure category	Failure rates (FIT)
λ_{dd} = Total Dangerous Detected failures	0.00
λ_{du} = Total Dangerous Undetected failures	1.60
λ_{sd} = Total Safe Detected failures	0.00
λ_{su} = Total Safe Undetected failures	156.99
$\lambda_{tot\ safe}$ = Total Failure Rate (Safety Function) = $\lambda_{dd} + \lambda_{du} + \lambda_{sd} + \lambda_{su}$	158.59
MTBF (Safety Function, single channel) = $(1 / \lambda_{tot\ safe}) + MTTR$	719 years
$\lambda_{no\ effect}$ = "No Effect" failures	128.01
$\lambda_{not\ part}$ = "Not Part" failures	0.00
$\lambda_{tot\ device}$ = Total Failure Rate (Device) = $\lambda_{tot\ safe} + \lambda_{no\ effect} + \lambda_{not\ part}$	286.60
MTBF (Device, single channel) = $(1 / \lambda_{tot\ device}) + MTTR$	398 years

Failure rates table according to IEC 61508:2010 Ed.2 :

λ_{sd}	λ_{su}	λ_{dd}	λ_{du}	SFF
0.00 FIT	156.99 FIT	0.00 FIT	1.60 FIT	98.99%

PFDavg vs T[Proof] table (assuming Proof Test coverage of 99%), with determination of SIL supposing module contributes ≤10% of total SIF dangerous failures:

T[Proof] = 1 year	T[Proof] = 14 years
PFDavg = 7.02 E-06 - Valid for SIL 3	PFDavg = 9.83 E-05 - Valid for SIL 3

PFDavg vs T[Proof] table (assuming Proof Test coverage of 99%), with determination of SIL supposing module contributes >10% of total SIF dangerous failures:

T[Proof] = 20 years
PFDavg = 1.40 E-04 - Valid for SIL 3

Systematic capability SIL 3.

Testing procedure at T-proof

The proof test shall be performed to reveal dangerous faults which are undetected by diagnostic. This means that it is necessary to specify how dangerous undetected faults, which have been noted during the FMECA, can be revealed during proof test.

Proof test consists of the following steps:

Steps	Action
1	Bypass the safety-related PLC or take any other appropriate action to avoid a false trip.
2	For each D1092D-069 channel or for D1092S-069 single channel, verify the input-output functionality for the two different applications: 1. SPST NO contacts (terminals "1" and "2" for 1 st Ch. Output; terminals "5" and "6" for 2 nd Ch. Output): supply each input channel (terminals "13" and "14" for 1 st Ch. Input; terminals "15" and "16" for 2 nd Ch. Input) and verify that the corresponding SPST NO contact is closed; then, shutdown each input channel and verify that the corresponding SPST NO contact is open (safe state). 2. SPST NC contacts (terminals "3" and "4" for 1 st Ch. Output; terminals "7" and "8" for 2 nd Ch. Output): supply each input channel (terminals "13" and "14" for 1 st Ch. Input; terminals "15" and "16" for 2 nd Ch. Input) and verify that the corresponding SPST NC contact is open; then, shutdown each input channel and verify that the corresponding SPST NC contact is closed (safe state).
3	Remove the bypass from the safety-related PLC or restore normal operation.

This test reveals almost 99 % of all possible Dangerous Undetected failures in the relay module.

Warning

D1092-069 series are isolated electrical apparatus installed into standard EN50022 T35 DIN Rail located in Safe Area/Non Hazardous Locations or Zone 2, Group IIC, Temperature Classification T4, Class I, Division 2, Groups A, B, C, D, Temperature Code T4 and Class I, Zone 2, Group IIC, IIB, IIA Temperature Code T4 Hazardous Area/Hazardous Locations (according to EN/IEC60079-15, FM Class No. 3611, CSA-C22.2 No. 213-M1987, CSA-E60079-15) within the specified operating temperature limits Tamb -20 to +60 °C, and connected to equipment with a maximum limit for AC power supply of 250 Vrms.

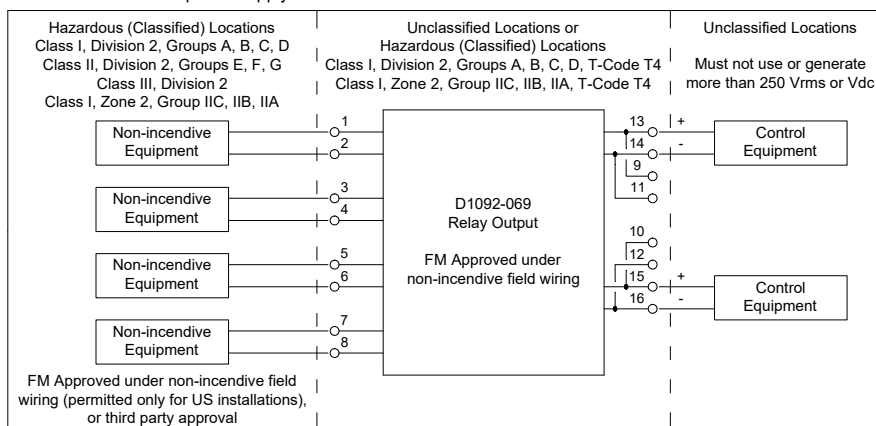

Non-incendive field wiring is not recognized by the Canadian Electrical Code, installation is permitted in the US only. For installation of the unit in a Class I, Division 2 or Class I, Zone 2 location, the wiring between the control equipment and the D1092-069 electrical apparatus shall be accomplished via conduit connections or another acceptable Division 2, Zone 2 wiring method according to the NEC and the CEC. Not to be connected to control equipment that uses or generates more than 250 Vrms or Vdc with respect to earth ground.

D1092-069 series must be installed, operated and maintained only by qualified personnel, in accordance to the relevant national/international installation standards (e.g. IEC/EN60079-14 Electrical apparatus for explosive gas atmospheres - Part 14: Electrical installations in hazardous areas (other than mines), BS 5345 Pt4, VDE 165, ANSI/ISA RP12.06.01 Installation of Intrinsically Safe System for Hazardous (Classified) Locations, National Electrical Code NEC ANSI/NFPA 70 Section 504 and 505, Canadian Electrical Code CEC) following the established installation rules. De-energize power source (turn off power supply voltage) before plug or unplug the terminal blocks when installed in Hazardous Area/Hazardous Locations or unless area is known to be nonhazardous. **Warning: substitution of components may impair Intrinsic Safety and suitability for Division 2, Zone 2. Warning: de-energize main power source (turn off power supply voltage) and disconnect plug-in terminal blocks before opening the enclosure to avoid electrical shock when connected to live hazardous potential. Explosion Hazard: to prevent ignition of flammable or combustible atmospheres, disconnect power before servicing or unless area is known to be nonhazardous.** Failure to properly installation or use of the equipment may risk to damage the unit or severe personal injury. The unit cannot be repaired by the end user and must be returned to the manufacturer or his authorized representative. Any unauthorized modification must be avoided.

Operation

D1092-069 relay modules are suitable for the switching of safety related circuits, providing isolation between the input and output contacts. D1092S-069, when the relay is de-energized, provides 1 SPST NO (Normally Open) contact and 1 SPST NC (Normally Closed) contact. D1092D-069, when the relays are de-energized, provides 2 independent circuits, each with 1 SPST NO (Normally Open) contact and 1 SPST NC (Normally Closed) contact. The channels and the relay contacts are completely isolated. For each channel, a "RELAY STATUS" yellow led lights when input is powered, showing that relay is energized and relay output contacts are closed (for SPST NO contact) or open (for SPST NC contact).

Installation

D1092-069 series are relay output modules housed in a plastic enclosure suitable for installation on T35 DIN Rail according to EN50022.

D1092-069 unit can be mounted with any orientation over the entire ambient temperature range, see "Installation of Electronic Equipments in the Cabinet" guide ISM0075 for detailed instructions. Electrical connection of conductors up to 2.5 mm² are accommodated by polarized plug-in removable screw terminal blocks which can be plugged in/out into a powered unit without suffering or causing any damage (**for Zone 2 or Division 2 installations check the area to be nonhazardous before servicing**).

The wiring cables have to be proportionate in base to the current and the length of the cable. On the section "Function Diagram" and enclosure side a block diagram identifies all connections. Identify the number of channels of the specific card (e.g. D1092S-069 is a single channel model and D1092D-069 is a dual channel model), the function and location of each connection terminal using the wiring diagram on the corresponding section, as an example:

For Model D1092S-069 connect positive input of channel 1 at terminal "13" and negative input at "14". For Model D1092D-069 in addition to channel 1 connections above, connect positive input of channel 2 at terminal "15" and negative input at "16". For Model D1092D-069 is also possible to control both channels with the same input (of channel 1 or 2), connecting a wired jumper between terminals "9" and "10" (for positive input duplication) and a wired jumper between terminals "11" and "12" (for negative input duplication). For Model D1092S-069, the terminals "1" and "2" are the two poles of SPST NO contact used to enable or disable the load circuit. Generally, the relay contact is used to break positive or negative supply line of load circuit. Then, connect wire of supply line at terminal "1" and link another wire at terminal "2" to continue the supply line of load circuit.

For Model D1092D-069 in addition to channel 1 connections above, use terminals "5" and "6" of channel 2 as two poles of SPST NO contact used to enable or disable the second load circuit.

For Model D1092S-069, the terminals "3" and "4" are the two poles of SPST NC contact used to enable or disable the load circuit. Generally, the relay contact is used to break positive or negative supply line of load circuit. Then, connect wire of supply line at terminal "3" and link another wire at terminal "4" to continue the supply line of load circuit.

For Model D1092D-069 in addition to channel 1 connections above, use terminals "7" and "8" of channel 2 as two poles of SPST NC contact used to enable or disable the second load circuit.

Installation and wiring must be in accordance to the relevant national or international installation standards (e.g. IEC/EN60079-14 Electrical apparatus for explosive gas atmospheres - Part 14: Electrical installations in hazardous areas (other than mines), BS 5345 Pt4, VDE 165, ANSI/ISA RP12.06.01 Installation of Intrinsically Safe System for Hazardous (Classified) Locations, National Electrical Code NEC ANSI/NFPA 70 Section 504 and 505, Canadian Electrical Code CEC), make sure that conductors are well isolated from each other and do not produce any unintentional connection.

Connect SPST relay contacts checking the load rating to be within the contact maximum rating (3 A, 250 Vac or 125 Vdc, 750 VA 120 W resistive load).

If necessary, to prevent relay contacts from damaging, an external protection (fuse or similar) should be connected.

A suitable protection must be chosen according to the relay breaking capacity diagram on data sheet.

The enclosure provides, according to EN60529, an IP20 minimum degree of mechanical protection (or similar to NEMA Standard 250 type 1) for indoor installation, outdoor installation requires an additional enclosure with higher degree of protection (i.e. IP54 to IP65 or NEMA type 12-13) consistent with the effective operating environment of the specific installation. Units must be protected against dirt, dust, extreme mechanical (e.g. vibration, impact and shock) and thermal stress, and casual contacts.

If enclosure needs to be cleaned use only a cloth lightly moistened by a mixture of detergent in water.

Electrostatic Hazard: to avoid electrostatic hazard, the enclosure of D1092-069 must be cleaned only with a damp or antistatic cloth.

Any penetration of cleaning liquid must be avoided to prevent damage to the unit. Any unauthorized card modification must be avoided.

Relay output contact must be connected to loads non exceeding category I, pollution degree I overvoltage limits.

Warning: de-energize main power source (turn off power supply voltage) and disconnect plug-in terminal blocks before opening the enclosure to avoid electrical shock when connected to live hazardous potential.

Start-up

Before powering the inputs of unit check that all wires are properly connected, also verifying their polarity. Check conductors for exposed wires that could touch each other causing dangerous unwanted shorts. Enabling each input, the corresponding "RELAY STATUS" yellow led must be lit and relay must be energized, so that SPST NO contact is closed and SPST NC contact is open. Indeed, disabling each input, the corresponding "RELAY STATUS" yellow led must be turned off and relay must be de-energized, so that SPST NO contact is open and SPST NC contact is closed.